



GasGard[®] XL Wall Mount Controller

Operating Manual



In North America, to contact your nearest stocking location, dial toll-free 1-800-MSA-INST
To contact MSA International, dial 1-412-967-3354

© MINE SAFETY APPLIANCES COMPANY 2010 - All Rights Reserved

This manual is available on the internet at www.msanet.com

Manufactured by

MSA NORTH AMERICA

P.O. Box 427, Pittsburgh, Pennsylvania 15230

(L) Y Rev 1

10091922

⚠ WARNING

THIS MANUAL MUST BE CAREFULLY READ BY ALL INDIVIDUALS WHO HAVE OR WILL HAVE THE RESPONSIBILITY FOR USING OR SERVICING THE PRODUCT. Like any piece of complex equipment, this instrument will perform as designed only if it is used and serviced in accordance with the manufacturer's instructions. OTHERWISE, IT COULD FAIL TO PERFORM AS DESIGNED AND PERSONS WHO RELY ON THIS PRODUCT FOR THEIR SAFETY COULD SUSTAIN SEVERE PERSONAL INJURY OR DEATH.

The warranties made by Mine Safety Appliances Company with respect to the product are voided if the product is not used and serviced in accordance with the instructions in this manual. Please protect yourself and others by following them. We encourage our customers to write or call regarding this equipment prior to use or for any additional information relative to use or repairs.

MSA Permanent Instrument Warranty

- 1. Warranty-** Seller warrants that this product will be free from mechanical defect or faulty workmanship for a period of 18 months from date of shipment, or one year from installation, whichever occurs first, provided it is maintained and used in accordance with Seller's instructions and/or recommendations. This warranty does not apply to expendable or consumable parts whose normal life expectancy is less than one year such as, but not limited to, non-rechargeable batteries, filament units, filter, lamps, fuses etc. The Seller shall be released from all obligations under this warranty in the event repairs or modifications are made by persons other than its own or authorized service personnel or if the warranty claim results from physical abuse or misuse of the product. No agent, employee or representative of the Seller has any authority to bind the Seller to any affirmation, representation or warranty concerning the goods sold under this contract. Seller makes no warranty concerning components or accessories not manufactured by the Seller, but will pass on to the Purchaser all warranties of manufacturers of such components.

THIS WARRANTY IS IN LIEU OF ALL OTHER WARRANTIES, EXPRESSED, IMPLIED OR STATUTORY, AND IS STRICTLY LIMITED TO THE TERMS HEREOF. SELLER SPECIFICALLY DISCLAIMS ANY WARRANTY OF MERCHANT ABILITY OR OF FITNESS FOR A PARTICULAR PURPOSE.
- 2. Exclusive Remedy-** It is expressly agreed that Purchaser's sole and exclusive remedy for breach of the above warranty, for any tortious conduct of Seller, or for any other cause of action, shall be the repair and/or replacement at Seller's option, of any equipment or parts thereof, which after examination by Seller is proven to be defective. Replacement equipment and/or parts will be provided at no cost to Purchaser, F.O.B. Seller's Plant. Failure of Seller to successfully repair any non-conforming product shall not cause the remedy established hereby to fail of its essential purpose.
- 3. Exclusion of Consequential Damage-** Purchaser specifically understands and agrees that under no circumstances will seller be liable to purchaser for economic, special, incidental or consequential damages or losses of any kind whatsoever, including but not limited to, loss of anticipated profits and any other loss caused by reason of non-operation of the goods. This exclusion is applicable to claims for breach of warranty, tortious conduct or any other cause of action against seller.

Table of Contents

Chapter 1,	
Product Introduction	1-1
Correct Use	1-1
Chapter 2,	
Description	2-1
General Overview	2-1
Control Unit	2-2
Wall Mount Enclosure	2-2
Figure 2-1. Enclosure	2-2
Power Supply	2-3
Backup Battery	2-3
Main Board	2-3
Display Board	2-4
Sensor Extension Board	2-4
Channel Board	2-4
Channel Relay Board	2-5
Front Panel	2-6
Graphic Display	2-6
Figure 2-2. Front Panel	2-6
Figure 2-3. Graphic Display	2-6
Control Push Buttons	2-7
Channel Status Info LEDs	2-7
Figure 2-4. Channel Status Info LEDs	2-7
Unit Status Info LEDs	2-9
Figure 2-5. Unit Status Info LEDs	2-9

Chapter 3,	
Installation	3-1
Mechanical Installation	3-2
Electrical Installation	3-2
▲ CAUTION	3-2
Figure 3-1. Mounting Drawing	3-2
Power Supply	3-3
Figure 3-2. Connecting the Main Supply	3-3
Sensor Connection	3-4
▲ CAUTION	3-4
Chapter 4,	
Operation	4-1
Basic Screen	4-1
Figure 4-1. Basic Screen	4-1
Status Info Symbols	4-2
Controls	4-4
Using the Hotkeys	4-5
Viewing Channel Information	4-6
Viewing Events Archive	4-7
List of Assigned Events	4-8
Chapter 5,	
Configuration	5-1
(1) System Menu	5-1
(2) Calibration Menu Direct Access	5-1
System Menu	5-2
Channel Number	5-3
Relay Board Identification Mark	5-3
Setting Icons	5-3
Description of Channel Parameters	5-4
Modifying Channel Parameters	5-6
Relay Setting Menu	5-8
Description of Relay Parameters	5-8
Example of Relay Configuration	5-10
Modifying Output Relays	5-10
Fixed Setting for Common Relays	5-12
General Setting Menu	5-12

Manual Calibration (4 - 20 mA)5-14

**Chapter 6,
Configuration Software6-1**

Installation and Start up6-1
Application6-2
 Menu Bar6-2
 Figure 6-1. Main Applications Screen6-2
Multilingual System6-3
Setting Up Channels6-4
 Figure 6-2. Setting up Channels6-4
Setting Up Output Relays6-5
 Figure 6-3. Setting up Output Relays6-5

**Chapter 7,
Maintenance7-1**

Table 7-1. Accessories and Spare Parts7-1

**Chapter 8,
Technical Specifications and Certifications .8-1**

Table 8-1. Technical Specifications8-1
Approvals8-1

**Appendix A,
Sensor ListA-1**

Table A-1. GasGard XL-compatible SensorsA-1

**Appendix B,
Wiring DiagramsB-1**

Figure B-1. Flamegard Flame DetectorB-1
Figure B-2. SafEye Open Path Gas DetectorB-1
Figure B-3. Ultima X (Two-wire)B-2
Figure B-4. Ultima X (Three-wire)B-2
Figure B-5. Ultima X IR SensorB-3

**Appendix C,
Individual Relay ConnectionsC-1**

Figure C-1. Individual Relay ConnectionsC-1

**Appendix D,
Terminal ConnectorsD-1**

Figure D-1. Main BoardD-1

Figure D-2. Sensor Extension BoardD-1

Figure D-3. Channel Relay BoardD-2

Chapter 1, Product Introduction

Correct Use

The GasGard XL Wall Mount Controller is a compact control unit that:

- connects with up to eight active combustible, toxic and/or oxygen sensors
- is used to monitor indoor industrial locations for the presence of combustible, explosive, toxic gases or air/vapor mixtures and oxygen content
- provides power to the sensors, signal conditioning and display of measured gas concentrations, alarm thresholds, outputs for alarm devices and self monitoring diagnostics
- is suitable for many applications and industrial areas
- provides simple installation, easy editing and copying functions
- is ideal for smaller, independent gas warning systems.

The user must carefully read and observe:

- this operating manual, particularly, the safety, use and operating instructions
- the national regulations applicable in the user's country, including requirements specific to explosive risk approval.

Use or alterations outside these instructions is considered as non-compliance.

WARNING

This product is supporting life and health. Incorrect use, maintenance or servicing can affect its function and seriously compromise the user's life. When turned ON for the first time, the controller performs a self-check. Do Not use the monitor if it fails the self-check, which is indicated by a failure light. Do Not use the monitor if it is damaged, improper servicing/maintenance has been performed, or if genuine MSA spare parts have not been used.

Chapter 2, Description

General Overview

The general-purpose control system enables:

- Combustible gas monitoring
 - for protecting operational plants and workers by monitoring atmospheres for potentially explosive gases/vapors in air before they reach the lower explosion limit and by activating alarms and initiating risk aversion measures.
- Oxygen monitoring
 - for protecting individuals by monitoring the atmosphere for oxygen deficiency or oxygen enrichment.
- Toxic gas monitoring
 - for protecting individuals by continuously monitoring the atmosphere for toxic gas concentrations.

NOTE: An alarm activates if set limit values are reached (e.g. minimum/ maximum concentration in the atmosphere).

Typical applications are:

- Chemical and petrochemical industry
- Paint and solvent industry
- Gas-processing industry
- Municipal areas.

Control Unit

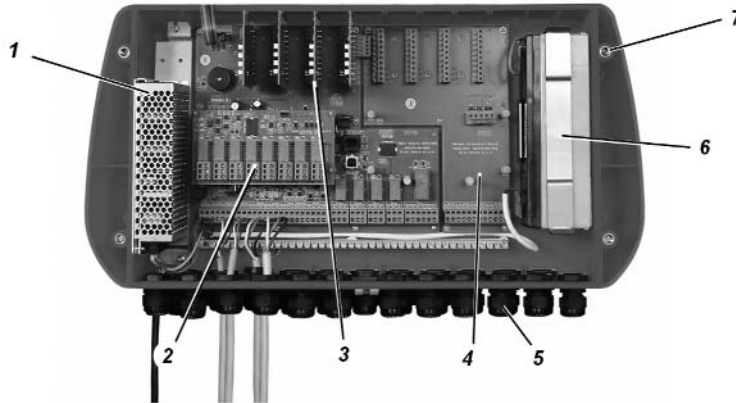

Figure 2-1. Enclosure

1	Power Supply	5	Cable entries
2	Channel Relay Board	6	Backup Battery
3	Channel Board	7	Enclosure with mounting holes
4	Sensor Extension Board		

Wall Mount Enclosure

The Control Unit:

- is housed in an ABS enclosure in accordance with IP 56 and NEMA 4X
- dimensions are 515 mm x 277 mm x 129 mm (20 x 11 x 5 inches)
- cable entry points are not provided, but are are predesigned on the bottom of the enclosure (0.75" or M20)
- front panel is molded with predesigned holes for fully equipped configuration (eight channels)
- is mounted by four screws (1/4 - 20 or M6).

Power Supply

- The 100 W power supply accepts main AC and DC power.
- In case of loss of main power, the power supply automatically switches to backup battery.
- Power source for detector is 24 VDC.

Backup Battery

Two batteries in series (12 VDC/2.2 Ah lead acid) can be used in the Control Unit as an option. The batteries supply 20 minutes of backup for eight catalytic combustible sensors.

To activate battery backup, the pc software must be configured. Go to Settings, Service Function, Device Settings. Check the Battery Backup box to activate, save and then download settings to the Control Unit.

Do not use primary non-rechargeable batteries.

Operation under back-up power is indicated by the Power LED blinking on the front panel.

Main Board

The Main board microcontroller includes:

- watchdog
- internal buzzer (85 dB)
- standard common outputs
- battery charger circuit.

All necessary information is stored on the Main board.

The following communications are possible:

- 1 Ethernet configurable for ModBus TCP/IP (galvanically isolated)
- 1 RS485 configurable for ModBus RTU (galvanically isolated)
- 1 USB configurable for ModBus RTU.

NOTE: Communication doesn't interfere with operation of the Control Unit.

- For SCADA visualization software, all three interfaces can be used.
- For service access, as a safety precaution, only the two ModBus RTU communications can be used.

Standard common outputs are incorporated:

- two SPDT (Single Pole Double Throw) relays common alarm (ALARM 1 and ALARM 2)
- one DPDT (Double Pole Double Throw) relay common fault
- two addressable common horn relays.

Display Board

The Display board, located on the back side of the lid, includes:

- microcontroller
- watchdog
- push buttons
- graphic display (128x64).

Sensor Extension Board

The sensor extension board is used to:

- attach channel boards
- connect internal communication.

NOTE: See Chapter 3, "Sensor Connection".

Channel Board

The channel boards are set to communicate with 4-20 mA transmitters.

Every board:

- includes four LEDs (A1, A2, Status, Power)
- attaches to the Channel connectors (four on the Main board, four on the Sensor Extension board).

Sensor power and connection is designed as "fail-safe" (wrong connection/configuration does not damage the remote sensor).

Channel Relay Board

Every Channel Relay board:

- provides eight output relays
- is connected to the Main board or Sensor Extension board (one by one) via connectors.

Relays are fully user-configurable from the front panel or connected PC via configuration software.

Two optional SPDT (Single Pole Double Throw) relays per channel (eight relays per four channels) are configurable for individual alarms:

- Normally open/closed
- Normally energized/de-energized
- Latching/non latching
- Increasing/decreasing
- N out of m voting
- Grouping

NOTE: Contacts are resistive load.

Front Panel

The Front Panel enables communication with the Control Unit and is used to:

- monitor the status of all connected field sensors
- determine system settings
- configure all settings.



Figure 2-2. Front Panel

1	Common LEDs	4	Alarm Acknowledgement
2	Alarm Reset	5	Graphic Display
3	Control Push Buttons	6	Channel Status Info LEDs

Graphic Display

The Control Unit has a large, 128 x 64 pixel graphic display which shows information for all channels. See Chapter 4 for symbol explanation.

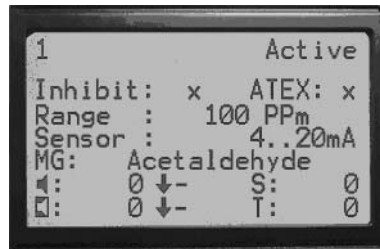
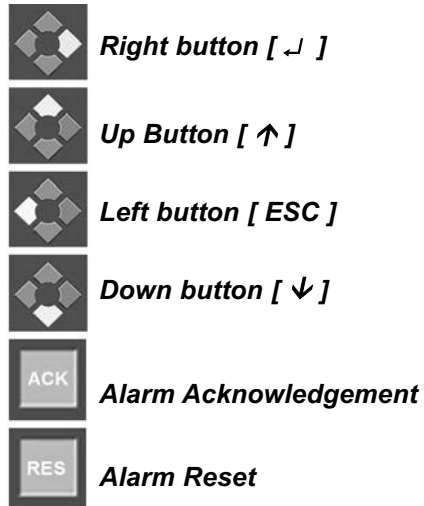

Figure 2-3. Graphic Display

Control Push Buttons

Using the control push buttons, the user can operate the menu prompt as shown below. For more information, see Chapter 4.



Channel Status Info LEDs

Each of the eight Control Channels has four LEDs for monitoring unit operating status.

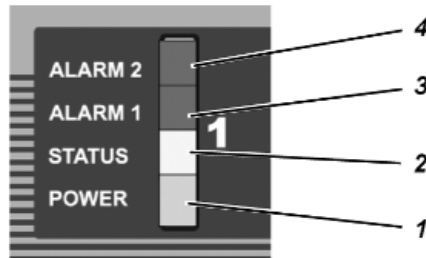

Figure 2-4. Channel Status Info LEDs

1. The green Power LED:
Channel is powered and enabled by the system.
2. The yellow Status LED:
Channel is in a fault condition.
 - Blinking LED (0.5 Hz):
Channel is disabled.
3. The red Alarm 1 LED:
First alarm level is reached. It further indicates the specific status:
 - 4 Hz blinking:
First alarm level is reached, but not yet acknowledged
 - Steady:
First alarm level is acknowledged, but still inside alarm range
 - 0.5 Hz blinking:
First alarm is configured as latching. Measured value is out of alarm level and not yet reset.
4. The red Alarm 2 LED:
Second alarm level is reached. It further indicates specific status:
 - 4 Hz blinking:
Second alarm level is reached, but not yet acknowledged
 - Steady:
Second alarm is acknowledged, but still inside alarm range
 - 0.5 Hz blinking:
Second alarm is configured as latching. Measured value is out of alarm level and not yet reset.

Unit Status Info LEDs

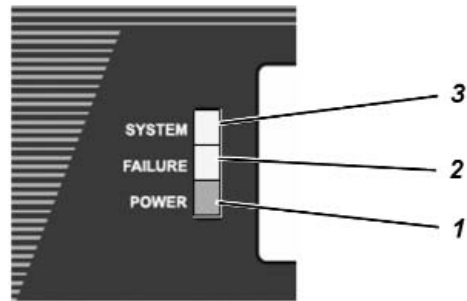

Figure 2-5. Unit Status Info LEDs

1. Green Power LED:
Control Unit is powered.
 - Blinking LED:
battery power supply.
2. Yellow Failure LED:
Sensor is in fault condition.
3. Yellow System LED:
Control Unit has a system fault.

Chapter 3, Installation

NOTE: Reference shipping documents and carton label to check that delivered components are correct before installation.

- The installation location for the Control Unit must be outside the potentially explosive area and free of corrosive gases.
- Sensors for use in the potentially explosive area must have the appropriate approval and be installed in accordance with all relevant local and national regulations.
- The gas warning system must be installed by qualified personnel after reading the supplied documentation.
- All relevant local and national regulations and instructions must be observed.

Mechanical Installation

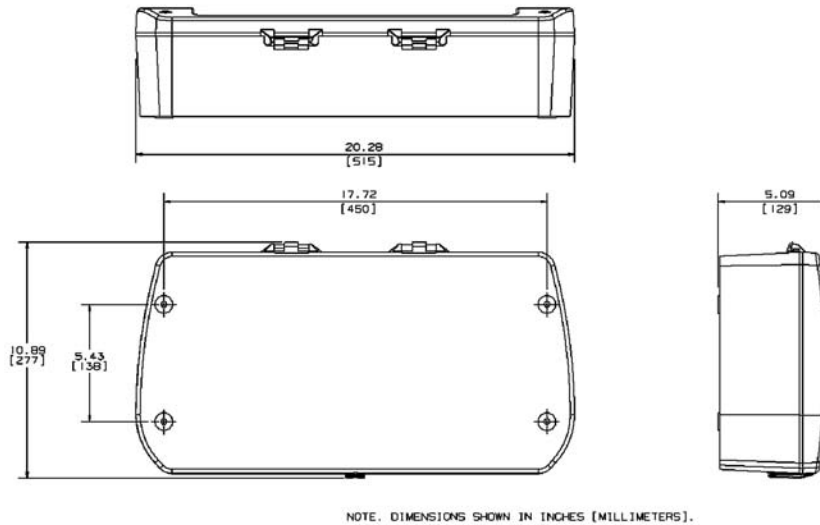

Figure 3-1. Mounting Drawing [dimensions in inches (mm)]

Mount the Control Unit as follows:

1. Mark holes for the four fixing screws as shown in FIGURE 3-1.
2. Drill four holes of appropriate diameter for the wall plugs.
3. Lift the front panel from the enclosure.
4. Attach the unit to the wall with the appropriate screws.
5. Return the lid to the resting position.

Electrical Installation

⚠ CAUTION

The control system must be installed in compliance with applicable regulations; otherwise, an unsafe condition may exist.

During installation, use the internal earth connection to ground the instruments.

If an external earth connection is permitted or demanded by the local authorities, it serves merely as additional earthing.

- Select an installation location that complies with the environmental conditions indicated in the technical data.
- When installing the Control Unit, the following conditions must be met to comply with the European EMC Directive
 - A fault-free ground or fault-free potential bonding conductor must be provided when connecting devices to the main power supply.
 - Ensure an appropriate supply voltage in accordance with EMC directives.
 - If the devices are supplied from a direct voltage (DC) source, the supply cable must be shielded.
 - All sensor and control cables must be shielded.
 - Shielded cables must have at least 80% coverage.
 - Control and sensor cables must be installed physically separate from power supply cables.
 - Shielded cables must be laid in a group. If cable lengths are to be extended using terminal boxes, the boxes must be shielded and internal connections must be kept as short as possible.
 - The control system can be simultaneously connected to AC voltage and 24 VDC (to enable an automatic power switch to 24 VDC voltage if the AC main supply fails).

Power Supply

- Standard power supply 110-230 VAC/24 VDC (100 W) is used to power internal circuits and attached sensors.
- A switch or circuit-breaker shall be included in the building installation in close proximity to the equipment and within easy reach of the operator. It shall be marked as the disconnecting device for the equipment.
- Main voltage is connected to terminal L (Line), N (Neutral), and ground.



Figure 3-2. Connecting the Main Supply

Sensor Connection

- The sensor must be connected to the terminals on the Main board or Sensor Extension board (See Appendices C and D for details).

⚠ CAUTION

Follow the instructions for components subject to damage from static electricity!

- Incorrect connection of the sensors will not damage the Control Unit or the sensor.
- The wiring diagrams for different sensors are shown in Appendix B. The sensors must be connected to the terminals using shielded cables.
- For the number of wires and the maximum cable length for each sensor type, refer to the specific sensor operating manual.

Chapter 4, Operation

The integrated operation/display unit:

- is the control system user interface
- displays alarms, warnings, and system parameters.
 - Connecting the operating unit to a PC enables a user-friendly operator interface.
 - Input fields are set up as selection fields as much as possible, with all known inputs displayed. Selection is cursor-controlled for easy display unit use.

Basic Screen

The basic screen displays information about active channel status (active, inhibit, and in service) including information about the system (system date and time).

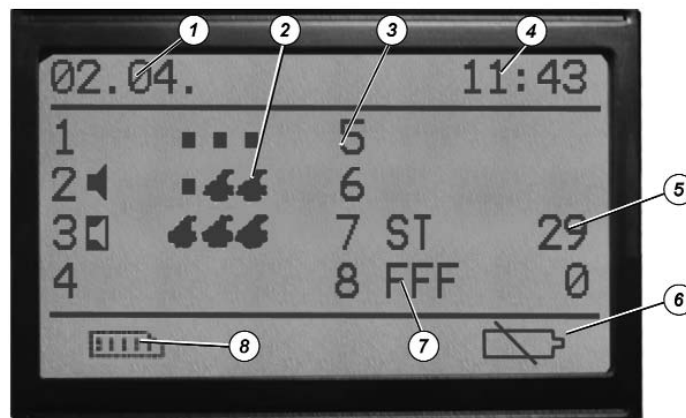

Figure 4-1. Basic Screen

1	System Date	5	Actual Value
2	FlameGard Status	6	Battery Status
3	Channel Number	7	Status Information
4	System Time	8	Events Archive

- **System Date and Time:**
Actual preset values for events archive (default is DD/MM)
- **Channel Number:**
Position of the channel board [counted from left to the right on the Main board (1 ... 4) and the Sensor Extension board (5 ... 8)].
- **Status Information:**
Information about channel status (alarm, fault, in service, etc.; see symbols)
- **Actual Value:**
Measured value of gas concentration.
- **Events Archive:**
Last 700 events (alarms, alarm acknowledgement and reset, faults, calibrations, etc.) are stored in memory and can be user-restored.

Status Info Symbols



Alarm 1:
Displays if alarm level is reached



Alarm 2:
Displays if alarm level is reached



Overrange:
Displays if channel signal is above the range (more than 105 % of full scale).



Underrange:
Displays if channel signal is below the range (less than -5 % of full scale)



Sensor Fault:
Displays if a sensor connection is broken or shorted or if signal falls below -10% of full scale



Internal Channel Fault:
Displays if Channel board has a system fault



In Service:
Displays if channel is in service mode (calibration)

**Inhibit:**

Displays if channel is inhibited

**STEL Alarm:**

Displays if STEL alarm is reached

**TWA Alarm:**

Displays if TWA alarm is reached

**Battery included and fully charged****Battery included but discharged**

(Symbol starts blinking if battery cable disconnected)

**Battery not included**







- If FlameGard is connected to the mA Channel board, the basic screen contains additional symbols for FlameGard status:

**FlameGard Detector is connected – No Flame****Warning - FlameGard Detector is in the first alarm condition****Alarm - FlameGard Detector is in second alarm condition**

- The channel where an alarm condition is reached first is identified by blinking value.

Controls

Located on the front panel are four control push buttons for Control Unit operation and configuration.

SYMBOL	PRESS BUTTON TO CAUSE UNIT TO:
 ENTER:	enter a lower menu or accept the change
 UP:	change values/options
 DOWN:	advance the cursor to the next position
 ESCAPE:	exit the upper menu or cancel the change
 ACKNOWLEDGEMENT:	disable the audible signal when alarm occurs
 RESET:	reset alarm relays to normal operating conditions when a measured value drops below the latching alarm level

Using the Hotkeys

Pressing some of the front panel control push buttons for a longer period accesses some additional basic screen features.



UP:

Pressing button for five seconds changes the language from English to one of 10 local languages and back



ESCAPE:

Pressing button for five seconds starts the GasGuard XL Selftest Process, testing the:

- LCD display
- LEDs
- internal buzzer.

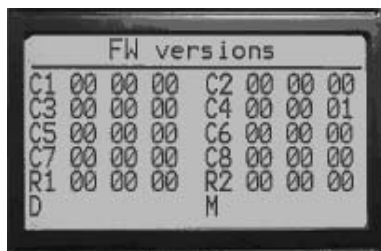

After the selftest, the firmware version of all assigned boards displays:

- C1 ...C8 - Channel boards
- R1 ... R2 - Relay boards
- D- Display board
- M – Main board.

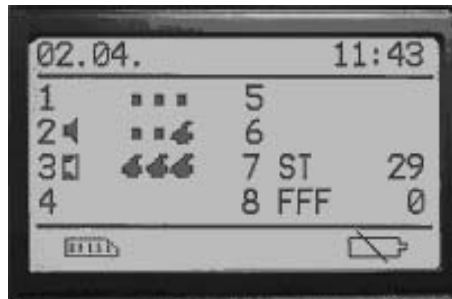

Viewing Channel Information



-  1. Viewing the Basic Screen, press [ENTER].
-  2. Select the channel by pressing [DOWN]
-  3. Press [ENTER] to confirm.

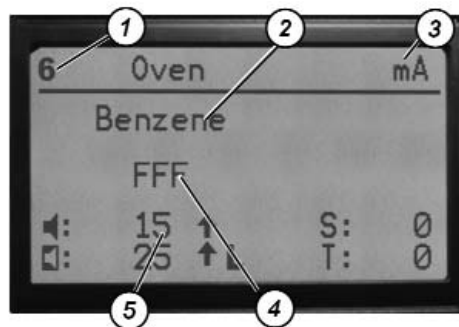



The next screen (above) shows channel information as:

1 - Channel number	4 - Measured gas value and unit or channel state
2 - Measured gas	5 - Preset alarm levels
3 - Active Channel Symbol	

NOTE: To change gas type, unit of measure or alarm levels, see the Quick Startup Guide (P/N 10095757) or Chapter 6.

Viewing Events Archive

-  1. Viewing the Basic Screen, press [ENTER].
-  2. Select the Event Archive button by pressing [DOWN]
-  3. Press [ENTER] to confirm.

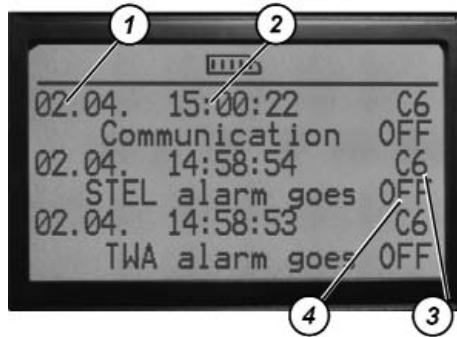

The next screen (above) shows channel information as:

1 - Event Date	3 - Channel Identification
2 - Event Time	4 - Event Description

-   4. Scroll the Events Archive by pressing [DOWN] or [UP].

List of Assigned Events

00	Device Turned On	27	Master Calibration Saved
01	Communication OFF	28	New Calibration Saved
02	Communication ON	29	Coil Relay 1 FAULT
03	Board Reset	30	Coil Relay 2 FAULT
04	Alarm1 ON	31	Coil Relay 3 FAULT
05	Alarm1 OFF	32	Coil Relay 4 FAULT
06	Alarm1 Acknowledgement	33	Coil Relay 5 FAULT
07	Alarm1 Reset	34	Coil Relay 6 FAULT
08	Alarm2 ON	35	Coil Relay 7 FAULT
09	Alarm2 OFF	36	Coil Relay 8 FAULT
10	Alarm2 Acknowledgement	37	Main Power Supply OFF
11	Alarm2 Reset	38	Main Power Supply N
12	UnderRange	39	Low Battery
13	OverRange	40	Battery FAULT
14	STEL alarm ON	41	Common Coil Relay Horn2 FAULT
15	STEL alarm OFF	42	Common Coil Relay Horn1 FAULT
16	STEL alarm Acknowledgement	43	Common Coil Relay Alarm2 FAULT
17	TWA alarm ON	44	Common Coil Relay Alarm1 FAULT
18	TWA alarm OFF	45	Common Coil Relay Fault FAULT
19	TWA alarm Acknowledgement	46	RAM Check FAULT
20	Sensor FAULT	47	ROM Check FAULT
21	System FAULT	48	System Password entered
22	Start of Calibration	49	Calibration Password entered
23	ZG accepted	50	Read FAULT
24	SG accepted	51	Write FAULT
25	FAULT of ZG result		
26	FAULT of SG result		

Chapter 5, Configuration

All GasGard XL Control Unit parameters can be configured by using:

- front panel control push buttons
- configuration software tool (see Chapter 6).

Two menus allow the user to change unit parameters:

(1) System Menu

The System menu:

- enables the user to change any parameter needed for application requirements
- is accessible only by an access password.

From the System menu, the user can enter additional Control Unit set-up menus:

- Relay Setting menu (to set up individual relay parameters)
- Calibration menu (to calibrate all channels)
- General Setting menu (to set up general unit parameters).

(2) Calibration Menu

The channel boards are configured to accept 4-20 mA input signals from two-wire or three-wire remote transmitters. The controller does not require any calibration.

NOTE: There are different passwords for the System menu and Calibration menu. Passwords can be set in the General Setting menu.

System Menu

The System menu allows full unit configuration:

- Modifying channel parameters
- Setting output relays (Relays Setting menu)
- Calibration (Calibration menu)
- General settings (General setting menu).



1. Simultaneously Press [ENTER] and [ESCAPE] and hold for one second.

- User is prompted to enter the password.



- Access Password is any number from 1 to 9999.
 - The factory password preset value is 123.
2. Use [UP]; [DOWN] and [ENTER] to enter the password.
3. Press [ENTER] to confirm the password.
- If password is valid, the System menu screen appears.

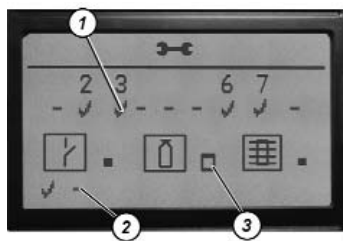

The System menu screen (above) displays:

1 - Channel Board Identification Mark

2 - Relay Board Identification Mark

3 - Setting Icons

1. Channel Number

If selected, the Channel Number allows user to set channel parameters.

NOTE: The Channel board Identification Mark must be selected by user to confirm that a channel board is inserted in the slot.

2. Relay Board Identification Mark

The Relay board Identification Mark must be selected by the user to confirm that a channel relay board is inserted in the slot:

- Left mark is for the first board (connected to the Main board), counting from the left
- Right mark is for the second board (connected to the Sensor Extension board), counting from the left).

3. Setting Icons

Marking icons enable the user to enter an additional submenu:



Relays setting menu (individual relays modification menu; see Chapter 5, "Modifying Channel Parameters").



Calibration menu (channel calibration; see Chapter 5, "Calibration")



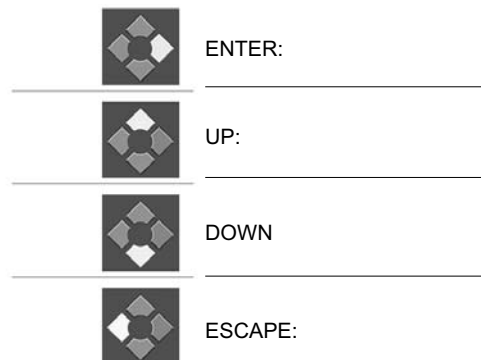

General setting menu (general parameters setting; see Chapter 5, "General Setting Menu")



1. Use control push buttons to select an item to set.
2. Press [ENTER] to confirm the selected item.
NOTE: A selected setting item is inverse and non-blinking.
NOTE: Pressing [ESCAPE] exits the System menu.

3. Use control push buttons to:

 - Accept changes and leave menu

 - Do not accept changes and leave menu

 - Return to the System menu.

Description of Channel Parameters

1. Enter the System menu (see Chapter 5, "System menu").
2. Use the control push buttons to select a channel number to modify.
3. Press [ENTER] to confirm.
 - The first of two configuration screens appears:



Inhibit: Marking inhibits the channel

ATEX: Marking presets alarm and relay conditions according to ATEX 94/9 requirements

Range: Defines measuring range and units

Sensor: Specifies sensor head to be connected

MG: Defines measuring gas



Alarm 1 value threshold and

Alarm 2 value threshold

(Default value in ATEX version)



Rising value will activate alarm



Falling value will activate alarm



Alarm is automatically deactivated



Alarm is latched until acknowledgement by [RESET].

NOTE: Use [DOWN] to toggle between the two screens.

- The second screen displays:



Delay: Time delay for alarm activating (0 – 180 seconds); In ATEX version default value is "0".

Hysteresis: Defines Alarm 1 and Alarm 2 hysteresis (from 0 to ± 2.0 % full scale).

Dead Band: Defines zero baseline (from 0 to ± 5.0 % full scale). Default is ± 2.0 %.

- If FlameGard is selected from the sensor list, the setting menu changes to the following screen. (The second screen contains only the "Delay" parameter.)



4. Use the control push buttons the set the following:



- Accept changes and leave menu



- Do not accept changes and leave menu



- Return to the System menu.

Modifying Channel Parameters

1. Enter into System menu (see Chapter 5, "System Menu").
2. Use control push buttons to select a channel number to modify and press [ENTER] to confirm.
 - First of configuration screens appear (left figure).

NOTE: Use [DOWN] to toggle between the two screens:

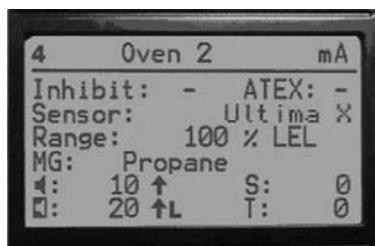

3. Use control push buttons to select required parameter.



Right (ENTER) button [↵]



Up Button [↑]



Left button [ESC]



Down button [↓]

4. Press [ENTER] to confirm the selected parameter.

5. Use the control push buttons to change parameter value.
6. Press [ENTER] to accept the changes.

NOTE: Pressing [ESCAPE] toggles to the upper menu.

- If FlameGard is selected from the sensor list, the Setting menu changes to the following single screen:



7. Use the control push buttons to set:



- Accept changes and leave menu



- Do not accept changes and leave menu



- Return to the System menu.

Relay Setting Menu

The Relay Setting menu enables the user to configure each relay in relation to each channel.

Description of Relay Parameters

1. Enter into the System menu.
2. In the System menu, select the item for "Relay Setting Menu" and press [ENTER] to confirm (see Chapter 5, "System Menu").



Right (ENTER) button [↵]



Up Button [↑]



Left button [ESC]



Down button [↓]

- The first of two configuration screens appears:

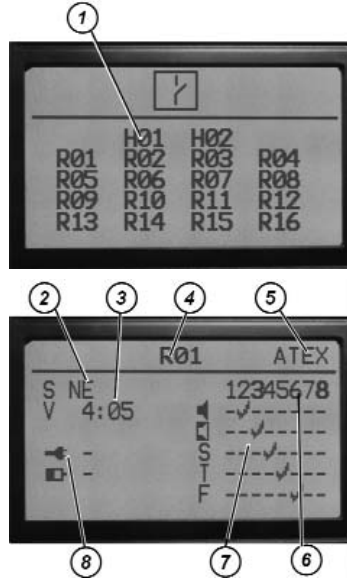

(1) Horn Relay Number (H01-H02):

Position of the horn relay on the Main board

(2) Relay Status:

Defines contacts position in de-energized status

NE - normally energized

ND - normally de-energized

(3) Relays Voting (V):

Allows user to set the voting of the selected relays

(4) Relay Number (R01-R16):

1 - 8 (Channel Relay board No. 1)
9 - 16 (Channel Relay board No. 2)

(5) ATEX Status:

Defines the selected relay is related to the channel being configured according to ATEX regulation. ATEX channels are displayed in bold numbers on the screen. Some relay parameters are limited [e.g., user can only set the normally energized (S: NE) selection]

(6) Channel Number:

Relates the relay to the selected channel (bold number indicates channel is configured according to ATEX regulation)

(7) Configuration Grid:

Setting the following items to the grid defines the status on the selected channel that activates the selected relay:



- Alarm 1 is set



- Alarm 2 is set



- STEL alarm 2 is set



- TWA alarm 2 is set



- Fault is set

(8) Battery/Power Relay Control:

Sets the relay that is energized when:



- Main power is OFF and Control Unit is battery powered



- Low battery voltage

Relay is set using these symbols:



- Not selected



- Selected

NOTE: Use [DOWN] to toggle between the two screens.

Example of Relay Configuration

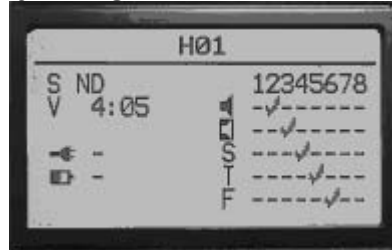

Relay HORN no. 1:

- is configured as normally de-energized (ND).
- is not activated if power is OFF or battery is depleted
- is voted if four out of five conditions are met and
- is energized if at least four of these conditions are met:
 - Channel 2 goes into alarm 1
 - Channel 3 goes into alarm 2
 - Channel 4 goes into STEL alarm
 - Channel 5 goes into TWA alarm
 - Channel 6 goes into FAULT.

Modifying Output Relays

1. Enter into the System menu.
2. From here, select "Relay Setting Menu" and press [ENTER] to confirm (see Chapter 5, "System Menu").
 - The first of the configuration screens appears.

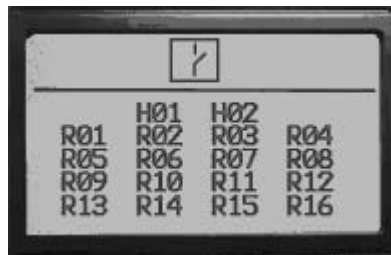

NOTE: Use [DOWN] to toggle between the two screens.

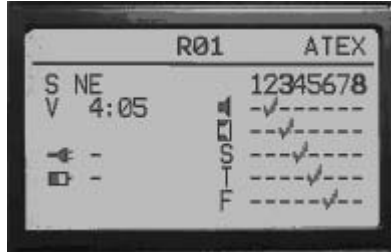

3. Use control push buttons to select and change required parameter.



Right (ENTER) button [↵]



Up Button [↑]



Left button [ESC]



Down button [↓]

4. Press [ENTER] to accept the parameter changes.

NOTE: Pressing [ESCAPE] returns unit to the upper menu.

5. Use control push buttons to:



- Accept changes and leave menu



- Do not accept changes and leave menu



- Return to the System menu.

NOTE: Common relays are not configurable. Their condition is set to the following fixed settings:

Fixed Setting for Common Relays

- Alarm 1 on any channel de-energizes common Alarm 1 relay on the Main board.
- Alarm 2 on any channel de-energizes common Alarm 2 relay on the Main board.
- Fault on any channel de-energizes Fault relay on the Main board.
- System fault de-energizes Fault relay on the Main board.

General Setting Menu

The General Setting menu allows the user to:

- configure access passwords for the system and Calibration menu
- set parameters.

1. Enter the System menu (see Chapter 5, "System Menu").
2. Use the control push buttons to select "General Setting Menu"; press [ENTER] to confirm.



Right (ENTER) button [↵]



Up Button [↑]



Left button [ESC]



Down button [↓]

- The first configuration screen appears:



1 - Language:	Setting required language
2 - System Psw:	Setting system password (factory preset password is: 123)
3 - Battery Back Up:	Select if battery backup is used
4 - Calibration Psw:	Setting calibration password (factory preset password is: 321)
5 - RESET Psw:	Setting alarm reset password (factory preset password is: 0)

NOTE: Setting any above password to 0 disables the password.

NOTE: Use [DOWN] to toggle to the second screen.

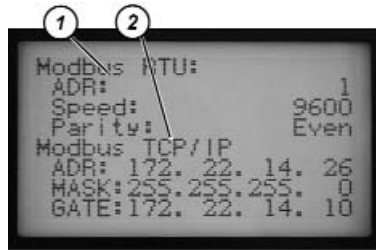

-
- 1 - **Modbus RTU:** Defines the RS 485 / USB communication parameters
 ADR – unit address
 Speed – communication speed
 Parity – setting the parity (Even/Odd)
-
- 2 - **Modbus TCP / IP:** Defines the Ethernet communications parameters
 ADR – unit IP address
 MASK - subnetwork mask
 GATE - gateway
-

NOTE: Use [DOWN] to toggle to the second screen.

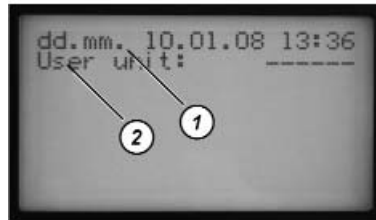

-
- 1 - **Time/Date:** Define time or date format (dd.mm. or mm.dd) can be selected
 - 2 - **User Unit:** Define measuring units
-

- 3. Use control push buttons to select and change required parameter.
- 4. Press [ENTER] to accept the parameter changes.

NOTE: Pressing [ESCAPE] toggles to the upper menu.

 **Right (ENTER) button [↵]**

 **Up Button [↑]**

 **Left button [ESC]**

 **Down button [↓]**

5. Use control push buttons to:

 - Accept changes and leave menu

 - Do not accept changes and leave menu

 - Return to the System menu.

Calibration

Calibration (4 - 20 mA)

Channel boards are configured to accept 4 - 20 mA input signals from two-wire or three-wire remote transmitters. The controller does not require any calibration.

During calibration of MSA's Ultima X Gas Monitors, the GasGard XL unit shows the following:

- For combustibles and toxics, if cal enable is ON, the 3.75 mA signal does not show a fault or underrange state on the GasGard XL unit. The display may show 0 or some negative value, depending on the Dead Band Around Zero setting.
- For oxygen, if cal enable is ON, the 21 mA signal causes the GasGard XL to go into an overrange status. As soon as the signal drops below 20.4 mA, the user must clear this state by pressing the RESET button.

Chapter 6, Configuration Software

Installation and Start up

For software installation, copy the [GASGARD XL] folder from the installation disc into the user's own directory.

NOTE: To run this software, Java module must be installed on the user's computer.

To launch the application, run the file "run.bat" from the user's directory.

NOTE: For easy access, create a shortcut on the computer desktop.

Hardware Requirements: PC, 512 MB RAM, CPU 1.5 GHz or higher

System Requirements: Windows 2000, Windows XP

Software Requirements: Java 6 SE or higher

Application

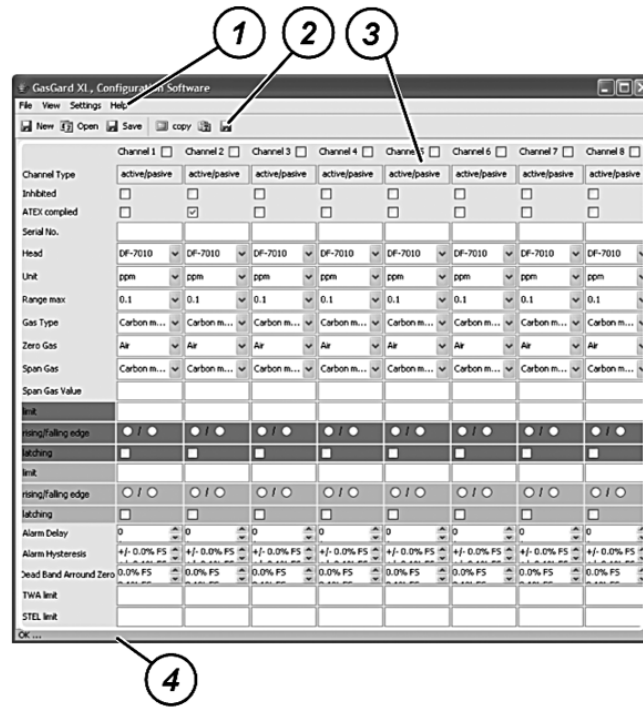

Figure 6-1. Main Applications Screen

The main Application screen contains four basic parts:

- | | |
|--------------|-----------------|
| 1 - Menu Bar | 3 - Main Screen |
| 2 - Toolbar | 4 - Status Bar |

Menu Bar

The menu bar has four pull down menus for application functions:

- File
- View
- Settings
- Help.

File

From the File menu, the user can:

- send or receive a configuration to the device unit
 - load or save a configuration to or from a file
 - print
 - exit the application
-

View

From the View menu, the user can switch between four basic screens and show or hide the toolbar and status bar.

NOTE: For easy access click on the toolbar icon to show a particular screen.

The user can select from the following options:

- Channels
 - Outputs
 - Calibration
 - Logs
-

Settings

From the Settings menu, the user can select from:

- Connection Type option
- Service Function option.

This application allows communication with devices via serial or USB port. The user must select one port to use for communication.

The Service Function option enables the user to set:

- language
- device address
- IP address
- mask.

The window also shows firmware version information.

Help

The Help menu assists the operator in using the application.

Multilingual System

The Configuration software is multilingual; for individual languages, use the "lang.properties" configuration file.

For additional local language configuration software, contact MSA or an MSA representative.

Setting Up Channels

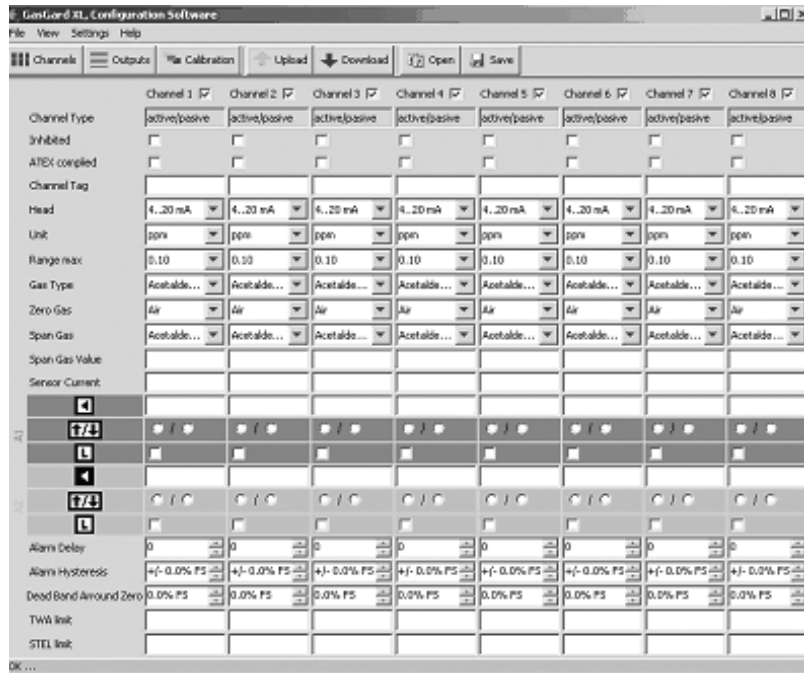

Figure 6-2. Setting up Channels

The window displays the status of all eight channels and allows configuration.

UPLOAD button: Allows user to upload configuration from the GasGuard XL unit

DOWNLOAD button: Allows user to download configuration to the GasGuard XL unit

OPEN Button: Opens the GasGuard XL configuration saved on the hard drive

SAVE button: Saves the GasGuard XL configuration to the hard drive

Setting Up Output Relays

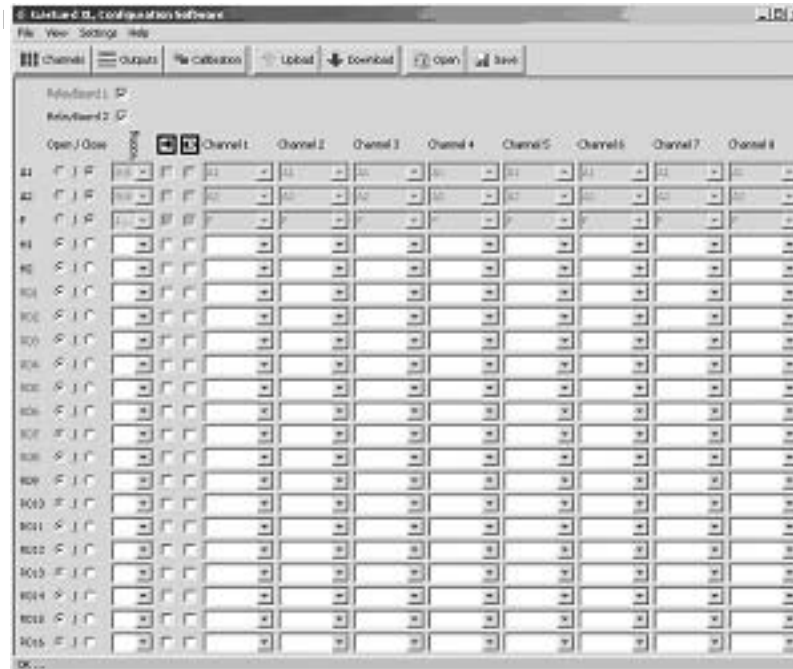

Figure 6-3. Setting up Output Relays

The window shows the outputs for the connected devices.

For each channel and each output relay, the user can select:

- Alarm 1
- Alarm 2
- STEL
- TWA or
- Fault.

For each selected channel, the drop-down menu enables voting selection. Voting can be set from 1:1 up to 42:42.

Chapter 7, Maintenance

- The Control Unit requires no special maintenance or cleaning, apart from verifying that it responds appropriately when performing sensor calibration checks.
- For SIL 2 (Safety Integrity Level) sensor applications, the calibration intervals must be reduced appropriately.
- Check the calibration of sensor(s) connected to the Control Unit according to your company's safety manager.

Table 7-1. Accessories and Spare Parts

DESCRIPTION	PART NO.
Sensor Extension Board (for channels 5 - 8)	10081676
Channel Relay Board	10081677
Channel Board 4 - 20 mA	10081674
GasGard XL, manual	10091922
EMC Filter (to be used with external. 24 VDC supply)	10081680
Back-up battery (2.2 Ah Kit)	10089924
Back-up battery	10093414
Display Board	10081679
Lid for housing with touch pad and gasket (w/o screws)	10081774
Flat ribbon cable (Main Board to Display Board)	10081775
Set of Lid fixing screws	10081909
Spare battery for Main Board	10031402
Main Board (channel 1 – 4)	10085436
Fuse 250 V	10089808
Spacers for relay channel board [set of 6]	10089913
Screw for Sensor Extension Board (need qty. 13)	10095004

Chapter 8, Technical Specifications and Certifications

Table 8-1. Technical Specifications

Power Supply	100 VAC - 240 VAC 50/60 Hz 2.5 A 100 W 24 VDC 4 A Main supply voltage fluctuations are not to exceed 10% of the nominal supply voltage
Sensor Power Supply	24 VDC
Connection Modes	2, 3 wires
Terminal Board	for copper wires up to 2.5 mm ²
Input Signals	4 – 20 mA
Output: Relay Contacts	5/6 A 240 VDC resistive
Alarm Thresholds	ALARM 1 (Warning) adjustable from 5 to 100% full scale (80% LEL for ATEX version) ALARM 2 (Alarm) adjustable from 5 to 100% full scale (80% LEL for ATEX version)
Electronic Speed of Response	< 1 sec to reach 100 % full scale
Span/Zero Drift	< ±0.5 % full scale ±1 digit/month
Accuracy/Repeatability	< ±1 % full scale ±1 digit
Operating Temperature	-10 to +50°C (14 to 122°F)
Storage Temperature	-20 to +75 °C (-4 to 167°F)
Ambient Humidity	0 to 90%, non condensing
Ingress Protection	IP 56, NEMA 4X
Dimensions (W x H x D)	515 x 277 x 129 mm (20 x 11 x 5 inches)
Weight	5 kg (7 kg with battery) [11 lbs. (15 lbs. with battery)]
Pollution Degree	2
Altitude	2000 m (6561 ft)
Installation Category	II

The GasGard XL Controller is for indoor use only.

The GasGard XL Controller's ethernet connection works at
10 MBit/s half-duplex only.

Approvals

cCSAus Certification Mark

Ordinary Location to UL/CSA 61010-1

with performance to the controller portions of

CSA 22.2 No. 152 and ISA 12.13 standards.

Appendix A, Sensor List

Table A-1. GasGard XL-compatible Sensors

4 – 20 mA TRANSMITTERS

FlameGard

SafEye

Standard 4-20 mA transmitter

ULTIMA X (2-wire)

ULTIMA X (3-wire)

ULTIMA X IR

Appendix B, Wiring Diagrams

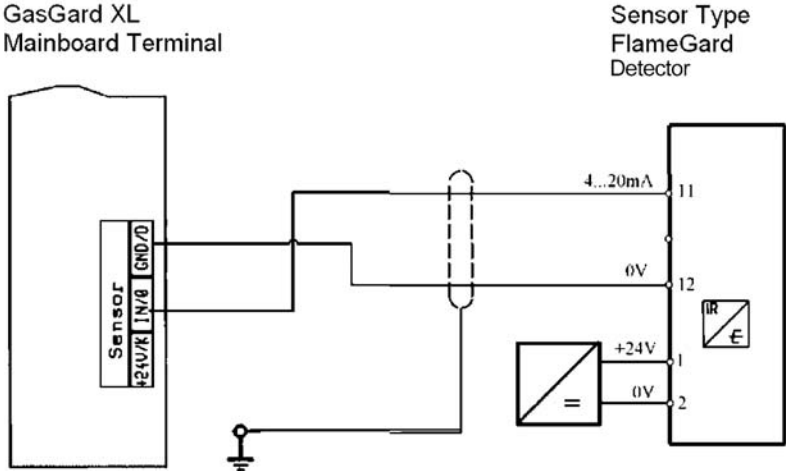

Figure B-1. Flamegard® Flame Detector

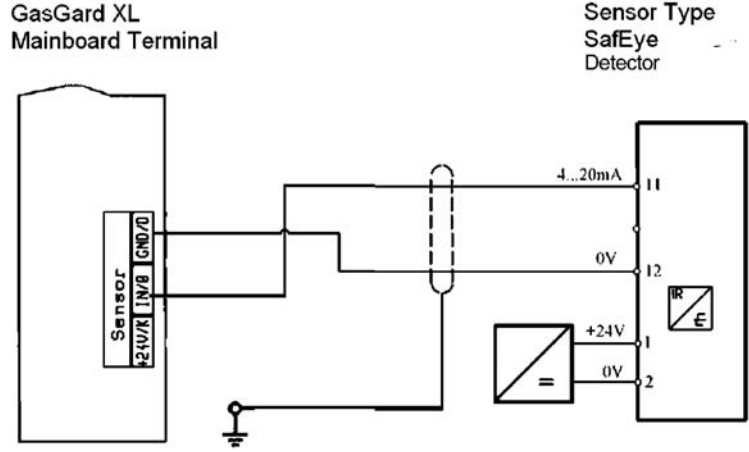

Figure B-2. SafEye® Open Path Gas Detector

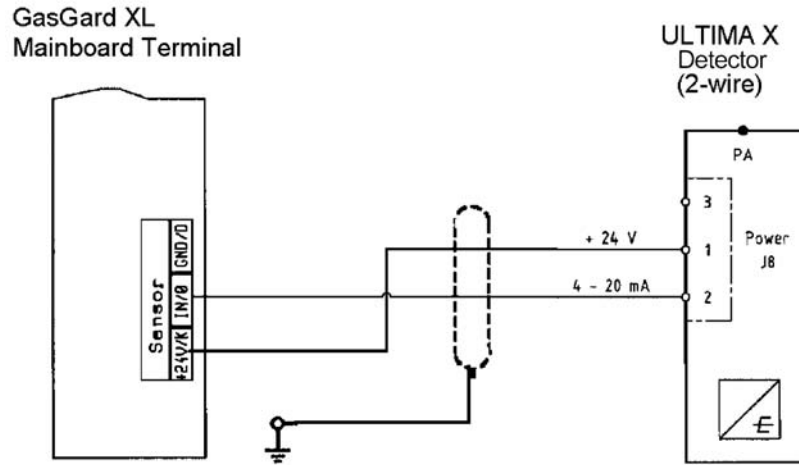

Figure B-3. Ultima® X (Two-wire)

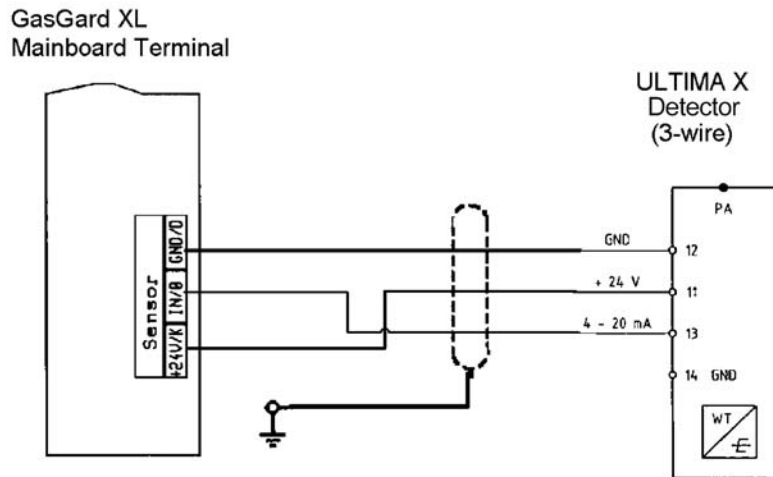

Figure B-4. Ultima X® (Three-wire)

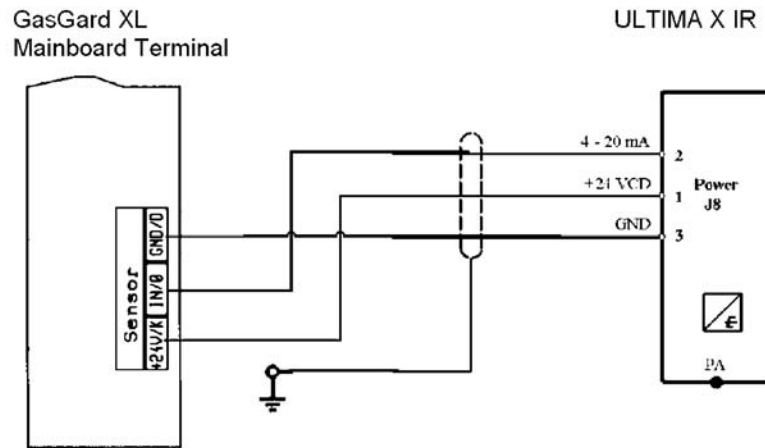

Figure B-5. Ultima® X IR Sensor

Appendix C, Individual Relay Connections

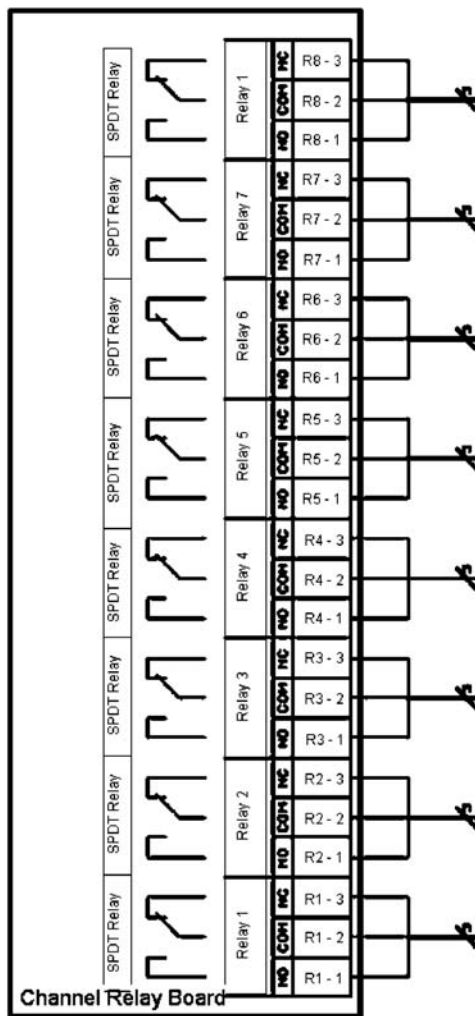

Figure C-1. Individual Relay Connections

Appendix D, Terminal Connectors

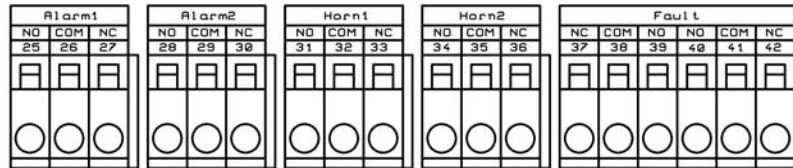
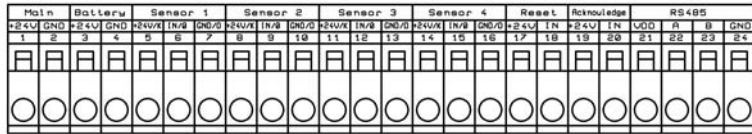

Figure D-1. Main Board

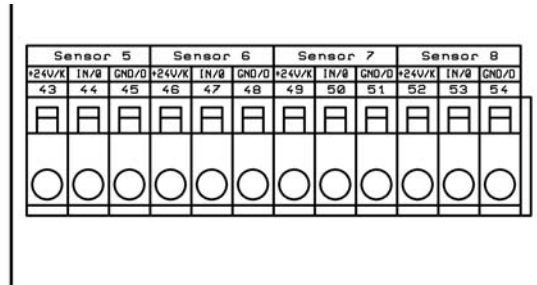

Figure D-2. Sensor Extension Board

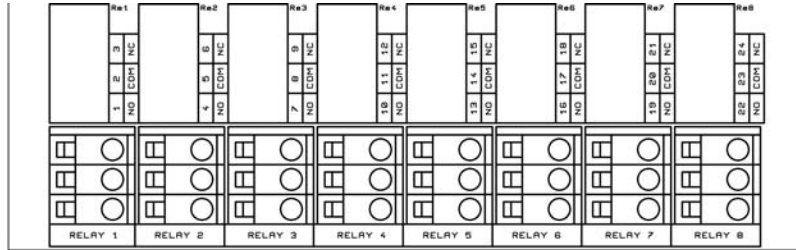

Figure D-3. Channel Relay Board