



# ModCon75<sup>®</sup> Controller

## Instruction Manual

### WARNING

THIS MANUAL MUST BE CAREFULLY READ BY ALL INDIVIDUALS WHO HAVE OR WILL HAVE THE RESPONSIBILITY FOR USING OR SERVICING THE PRODUCT. Like any piece of complex equipment, this instrument will perform as designed only if it is used and serviced in accordance with the manufacturer's instructions. OTHERWISE, IT COULD FAIL TO PERFORM AS DESIGNED AND PERSONS WHO RELY ON THIS PRODUCT FOR THEIR SAFETY COULD SUSTAIN SEVERE PERSONAL INJURY OR LOSS OF LIFE.

The warranties made by Mine Safety Appliances Company with respect to the product are voided if the product is not used and serviced in accordance with the instructions in this manual. Please protect yourself and others by following them. We encourage our customers to write or call regarding this equipment prior to use or for any additional information relative to use or repairs.

In North America, to contact your nearest stocking location, dial toll-free 1-800-MSA-INST  
To contact MSA International, dial 1-412-967-3354

MINE SAFETY APPLIANCES COMPANY 2010 - All Rights Reserved

This manual is available on the internet at [www.msanet.com](http://www.msanet.com)

Manufactured by

## MSA NORTH AMERICA

P.O. Box 427, Pittsburgh, Pennsylvania 15230

## MSA Permanent Instrument Warranty

- 1. Warranty-** Seller warrants that this product will be free from mechanical defect or faulty workmanship for a period of eighteen (18) months from date of shipment or one (1) year from installation, whichever occurs first, provided it is maintained and used in accordance with Seller's instructions and/ or recommendations. This warranty does not apply to expendable or consumable parts whose normal life expectancy is less than one (1) year such as, but not limited to, non-rechargeable batteries, sensor elements, filter, lamps, fuses etc. The Seller shall be released from all obligations under this warranty in the event repairs or modifications are made by persons other than its own or authorized service personnel or if the warranty claim results from physical abuse or misuse of the product. No agent, employee or representative of the Seller has any authority to bind the Seller to any affirmation, representation or warranty concerning the goods sold under this contract. Seller makes no warranty concerning components or accessories not manufactured by the Seller, but will pass onto the Purchaser all warranties of manufacturers of such components. **THIS WARRANTY IS IN LIEU OF ALL OTHER WARRANTIES, EXPRESSED, IMPLIED OR STATUTORY, AND IS STRICTLY LIMITED TO THE TERMS HEREOF. SELLER SPECIFICALLY DISCLAIMS ANY WARRANTY OF MERCHANTABILITY OR OF FITNESS FOR A PARTICULAR PURPOSE.**
- 2. Exclusive Remedy-** It is expressly agreed that Purchaser's sole and exclusive remedy for breach of the above warranty, for any tortious conduct of Seller, or for any other cause of action, shall be the repair and/ or replacement at Seller's option, of any equipment or parts thereof, which after examination by Seller is proven to be defective. Replacement equipment and/ or parts will be provided at no cost to Purchaser, F.O.B. Seller's Plant. Failure of Seller to successfully repair any nonconforming product shall not cause the remedy established hereby to fail of its essential purpose.
- 3. Exclusion of Consequential Damage-** Purchaser specifically understands and agrees that under no circumstances will seller be liable to purchaser for economic, special, incidental or consequential damages or losses of any kind whatsoever, including but not limited to, loss of anticipated profits and any other loss caused by reason of non-operation of the goods. This exclusion is applicable to claims for breach of warranty, tortious conduct or any other cause of action against seller.

## General Warnings

### WARNING

1. The Controller described in this manual must be installed, operated and maintained in strict accordance with its labels, cautions, warnings, instructions, and within the limitations stated.
2. The Controller must be located in non-hazardous areas.
3. Use only genuine MSA replacement parts when performing any maintenance procedures provided in this manual. Failure to do so may seriously impair instrument performance. Repair or alteration of the ModCon75 Controller beyond the scope of these maintenance instructions or by anyone other than authorized MSA service personnel, could cause the product to fail to perform as designed and persons who rely on this product for their safety could sustain serious personal injury or loss of life.
4. If a portion of the system fails, remaining system functions may not operate properly. In this case, do not use the system until proper repairs are made.

**Failure to follow the above can result in serious personal injury or loss of life.**

# Table of Contents

<b>Chapter 1,</b>	
<b>Overview</b>	<b>1-1</b>
Introducing the ModCon75 Controller	1-1
Figure 1-1. The ModCon75 System	1-1
Technical Description	1-2
ModCon75 Controller	1-2
Operating Panel	1-2
I/Os	1-3
Communications	1-3
RS232	1-3
Additional Communication Port	1-3
Programming	1-3
PLC Application	1-4
HMI Application	1-4
<b>Chapter 2,</b>	
<b>Mounting</b>	<b>2-1</b>
Before Installation	2-1
Safety and Environmental Guideline	2-2
Mounting	2-2
Figure 2-1. Vision Connectors and Mounting Brackets	2-1
▲ WARNING	2-2
Figure 2-2. ModCon75 Controller Panel Cut-out —Front View	2-3
Figure 2-3. Earth Assembly	2-3
Figure 2-4. Panel Mounted—Rear View	2-4
RS232 to RS422/RS485 Isolated Universal Converter	2-5
Features	2-5
Figure 2-5. Function Diagram	2-5
Wiring Connections	2-6
Top Connectors	2-6
Figure 2-6. Top Connectors	2-6
Bottom Connectors	2-7
Figure 2-7. Bottom Connectors	2-7

RS232 Wiring Considerations .....	2-8
RS485 Wiring Considerations .....	2-8
Figure 2-8. R-J11 Pin-out .....	2-8
DIP Switch Settings .....	2-9
Figure 2-9. RS485 Terminal Wiring .....	2-9
Table 2-1. Specifications of RS232 to RS485 Isolated Universal Controller .....	2-10
Figure 2-10. Dip Switch Settings .....	2-10
Figure 2-11. Mechanical Dimensions .....	2-11

### **Chapter 3, Power Supply .....3-1**

Safety Considerations .....	3-1
Wiring the Power Supply .....	3-1
Earthing the Power Supply .....	3-2
Figure 3-1. Power Supply Wiring .....	3-2
▲ WARNING .....	3-1

### **Chapter 4, I/O Modules .....4-1**

Snap-in I/O Modules .....	4-1
Features .....	4-1
Installing a Snap-in I/O Module .....	4-1
Removing a Snap-in I/O Module .....	4-2
▲ WARNING .....	4-1
User Safety and Equipment Protection Guidelines ...	4-2
Figure 4-1. Installing a Snap-in I/O Module .....	4-2
Environmental Considerations .....	4-3
Wiring .....	4-3
▲ WARNING .....	4-3
Wiring Procedures .....	4-4
I/O Wiring—General .....	4-4
Digital Inputs .....	4-4
▲ CAUTION .....	4-4
Digital Outputs .....	4-5
Wiring Power Supplies .....	4-5
Relay Outputs .....	4-5
Figure 4-2. Digital Inputs Used as pnp (Source) ..	4-5

Increasing Contact Life Span .....	4-6
Figure 4-3. Relay Outputs .....	4-6
Transistor Outputs .....	4-7
Figure 4-4. Increasing Contact Life Span .....	4-7
Figure 4-5. Transistor Outputs .....	4-8
Table 4-1. Snap-in I/O Module Technical Specifications .....	4-9

## **Chapter 5, Communications .....5-1**

RS232 .....	5-1
Figure 5-1. RS232 Port Printout .....	5-1

## **Chapter 6, Operating Instructions .....6-1**

Power up Screen .....	6-1
Figure 6-1. Power-up Screen .....	6-1
Main Menu Screen .....	6-2
Table 6-1. Keypad Functions .....	6-2
Figure 6-2. Main Menu Screen .....	6-2
F1-Add Units to Network .....	6-3
Figure 6-3. Password Entry .....	6-3
Figure 6-4. Add Units to the Network .....	6-4
Screen Displaying Node IDs Found .....	6-5
Figure 6-5. Node IDs Found .....	6-5
F2-Add Unit Setpoints .....	6-6
Figure 6-6. Allows Users to Set Enabled or Disabled Alarms .....	6-6
▲ WARNING .....	6-6
Figure 6-7. Allows Users to Set Increasing or Decreasing Alarms .....	6-7
Figure 6-8. Allows users to Set Latching / Non-latching Alarms .....	6-7
Figure 6-9. Allows Users to Assign Zone Control Relays to Caution, Warning and Alarm Setpoints for Sensors 1, 2, and 3 ...	6-8
Figure 6-10. Current Set-point values Read from the Selected Ultima X3 Unit ....	6-9

Figure 6-11. Sensor 1 Preset Screen	6-9
Figure 6-12. Sensor 2 Preset Screen	6-10
Figure 6-13. Sensor 3 Preset Screen	6-10
Figure 6-14. Displays all Presets before Downloading to the Unit	6-11
Figure 6-15. Verification Screen	6-12
▲ WARNING	6-12
F3-Main Data Screen	6-13
Figure 6-16. Main Data Screen	6-13
Figure 6-17. All Clear Status Screen	6-13
F4-Display Setpoints (view only)	6-14
Figure 6-18. Display Only Setpoints	6-14
F5- Password Editor	6-15
Figure 6-19. Password Editor	6-15
F6- Modbus Alarms	6-16
Figure 6-20. Modbus Alarms	6-16
F7- Fault Status	6-17
Figure 6-21. Fault Status	6-17
F8- Zone Editor	6-18
Figure 6-22. Zone Editor - Set Relays as Latched or Unlatched	6-18
F9- Remote Remote Relay Editor (Optional: Requires Remote Relay Modules)	6-19
Optional: Remote Relay units	6-19
Figure 6-23. Remote Relay Editor	6-19
▲ WARNING	6-19
F10-Network Settings	6-20
Figure 6-24. F10 - Network Settings	6-20

## **Chapter 7, Operating Panel Options . . . . .7-1**

Adjusting the LCD Screen Contrast	7-1
Printing Customized Slides Using Templates	7-2
Labeling Slides	7-2
Removing and Inserting Slides	7-2
Removing a Slide	7-2
Inserting a Slide	7-2
▲ CAUTION	7-2

**Chapter 8,  
Technical Specifications .....8-1**

Table 8-1. ModCon75 Specifications .....8-1

Figure 8-1. Dimensions .....8-2

**Appendix A,  
Port 3 Ethernet Port / OPC Server .....A-1**

**Appendix B,  
Register Maps .....B-1**

▲ WARNING .....B-1

Function Description – MI273 through MI297

– Signed Integer .....B-8

Function Description – MI450 through MI474

– Signed Integer .....B-9

Function Description – MI525 through MI599

– Signed Integer .....B-9

**Appendix C,  
Remote Relay Modules .....C-1**

Table C-1. Remote Relay Module Specifications .C-2

Figure C-1. Power Supply, pnp (source) Inputs ...C-4

Figure C-2. Relay Outputs .....C-4

Jumper Settings .....C-5

Table C-2. JP1 Digital Inputs Type .....C-5

Table C-3. JP2 Digital Inputs Voltage .....C-5

Table C-4. JP5, JP6 Power Supply Voltage ....C-5

Table C-5. JP3 Analog Input Type .....C-5

▲ CAUTION .....C-5

Figure C-3. Shown Jumper Settings Cause

the Controller to Function as Follows .....C-6

Figure C-4. Opening the Controller Enclosure ...C-7

**Appendix D,  
Event Retrieval Tools .....D-1**



# Chapter 1, Overview

## Introducing the ModCon75 Controller

The ModCon75 Controller:

- is a programmable logic controller with an integral operating panel
- offers Modbus communications and a real-time clock
- operating panels contain a graphic LCD screen and a keypad:
  - The LCD screen displays:
    - operator instructions
    - alarms
    - real-time variable system information.



*Figure 1-1. The ModCon75 System*

- Two types of I/O modules are compatible with ModCon75 Controllers:
  - Snap-in I/O Modules plug directly into the back of a ModCon75 Controller for a self-contained PLC unit with a local I/O configuration (integral to ModCon 75 Controller).
  - Remote Relay Modules can also be easily integrated to greatly extend the system's external notification capacity.
- These features combine to offer a cost-effective solution for mid-size industrial applications requiring:
  - operator interface
  - the ability to control small to medium processes according to time and ambient conditions.

## **Technical Description**

### **ModCon75 Controller**

- Dimensions:  
260 x 155 x 72 mm (10.24 x 6.1 x 2.8")
- Mounting:  
Panel-mounted via brackets
- Power Supply:  
12 or 24 VDC controller unit  
24 VDC for RS232 to RS485 converter
- Real-time Clock (RTC):  
Enables time and date controlled functions
- Battery Back-up:  
Protects real-time clock (RTC) and all data, including variable data.

### **Operating Panel**

- Contains a graphic screen and keypad:
  - LCD Screen Displays:
  - Alphanumeric Keypad contains:
    - six softkeys
    - nine function keys.

NOTE: To label keys, insert keypad slides according to Chapter 7, "Operating Panel Options".

### **I/Os**

- 16 digital pnp or npn inputs available.
- 10 relay outputs available.

NOTE: All I/O technical specifications are provided in Chapter 4. Not all inputs are used in the standard ModCon75 Controller.

### **Communications**

#### **RS232**

- The controller has two COM ports which may be used to:
  - download programs from a PC
  - establish communications with devices using RS232 protocol.

#### **Additional Communication Port**

- The additional communication channel has been set up with an Ethernet port.

NOTE: Information regarding other communication options can be obtained from MSA Customer Service.

### **Programming**

This programming function should only be used by an authorized MSA Service Representative.

- ModCon75 Controller programs have PLC and HMI applications.
- Both applications are programmed via a PC using proprietary software.

### **PLC Application**

- enables the user to perform automation tasks
- has an application memory of up to 1000K.

### **HMI Application**

- The HMI application customizes the operator interface to:
  - assign functions to the keypad keys
  - enable the operator to enter data via the controller keypad
  - create and display text, graphic images, and variable system data on the ModCon75 screen in response to run-time conditions.
- An HMI application can typically include up to 255 Displays, each with the ability to display text, graphic images, and variables.
  - Variables allow the user to display system data on the ModCon75 LCD screen:
    - bit, integer, and timer values
    - times and dates
    - I/O status and values
    - text from the variable text display list.
  - Variables can also use a graphic image or a bar graph to represent a value or range of values.
  - Typically, 12 fonts in a variety of languages may be installed and used in text messages.
  - When the VisiLogic program is complete, the programmer downloads it into the controller.

## Chapter 2, Mounting

### Before Installation

- Check the contents of the Controller Kit.
- Standard kits contain (FIGURE 2-1):
  - the controller (includes panel and Snap-in I/O module)
  - the RS232 to RS485 converter
  - a three-pin power supply connector
  - four mounting brackets, each with an inserted screw.
- Other items in the kit include:
  - an envelope containing a wire with a ring cable shoe
  - other hardware that may be used to earth the controller's power supply
  - a rubber seal already seated in back of the operating panel
  - a communication cable
  - two sets of keypad slides to be used for labeling the keypad keys
    - One set of slides is already installed in the operating panel.
- this manual.

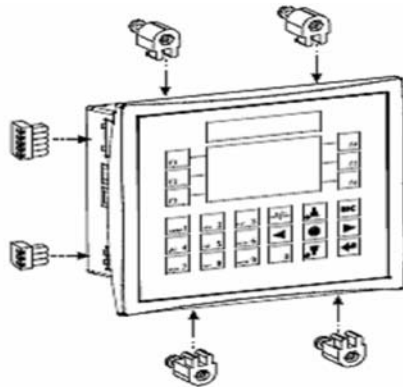

**Figure 2-1. Vision Connectors and Mounting Brackets**

## Safety and Environmental Guideline

### **⚠ WARNING**

This is a general-purpose (GP) monitor and can be a source of ignition. Install, locate, and operate only in a non-hazardous area and in accordance with all applicable codes.

Read and follow all instructions, warnings, and cautions pertaining to this gas monitor.

Failure to follow this warning can cause ignition of explosive environments, resulting in serious personal injury or loss of life.

- Do not install in areas with:
  - excessive or conductive dust
  - corrosive or flammable gas
  - moisture or rain
  - excessive heat
  - regular impact shocks or excessive vibration.
- Do not place in water or allow water to leak onto the controller.
- Do not allow debris to fall inside the unit during installation.
- Do not touch live wires.
- **Double-check** all the wiring before turning ON the power supply.
- Stay as far as possible from high-voltage cables and power equipment.
- Allow a minimum of 10 mm of space for ventilation between the top and bottom edges of the controller and the enclosure walls.

## Mounting

NOTE: The mounting panel cannot be more than 5 mm thick.

- To maximize system performance, avoid electromagnetic interference by:
    - mounting the controller on a metal panel
    - earthing the power supply according to FIGURE 2-3.
1. Make a panel cut-out for your ModCon75 Controller

- See FIGURE 2-2 for cut-out dimensions.
2. If you are mounting the controller on a metal panel, earth the power supply:
    - a. Bore a hole (FIGURE 2-2) that suits the NC6-32 screw supplied with the controller kit.
    - b. Scrape the panel paint away from the contact area to ensure a conductive connection.
    - c. Drive the screw into the hole.

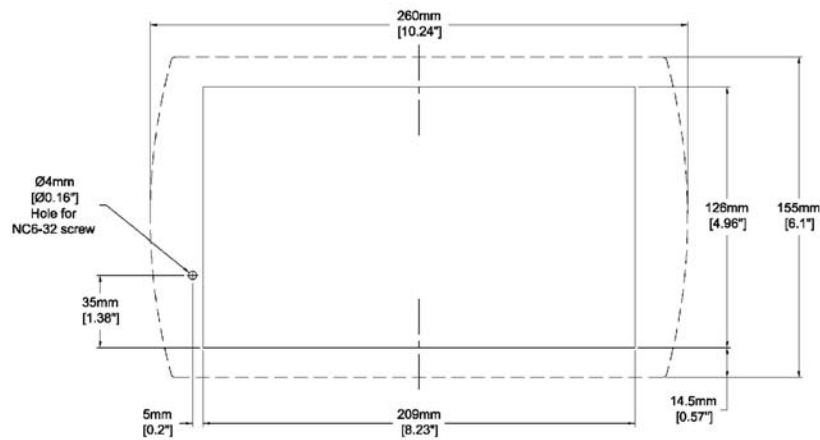

**Figure 2-2. ModCon75 Controller Panel Cut-out—Front View**

- d. On the screw's shank, place the following hardware in this order: washer, ring cable shoe, second washer, spring, and nut; as shown in FIGURE 2-3.

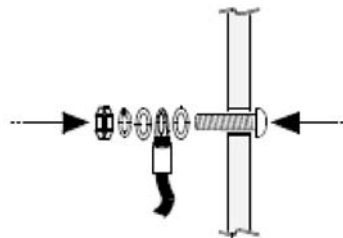

**Figure 2-3. Earth Assembly**

3. Slide the controller into the cut-out, ensuring that the rubber seal is in place.
4. Push the four mounting brackets into their slots on the sides of the controller as shown in FIGURE 2-1.
5. Tighten the bracket screws against the panel.
- When properly mounted, the controller is squarely situated in the panel cut-out as shown in FIGURE 2-4.

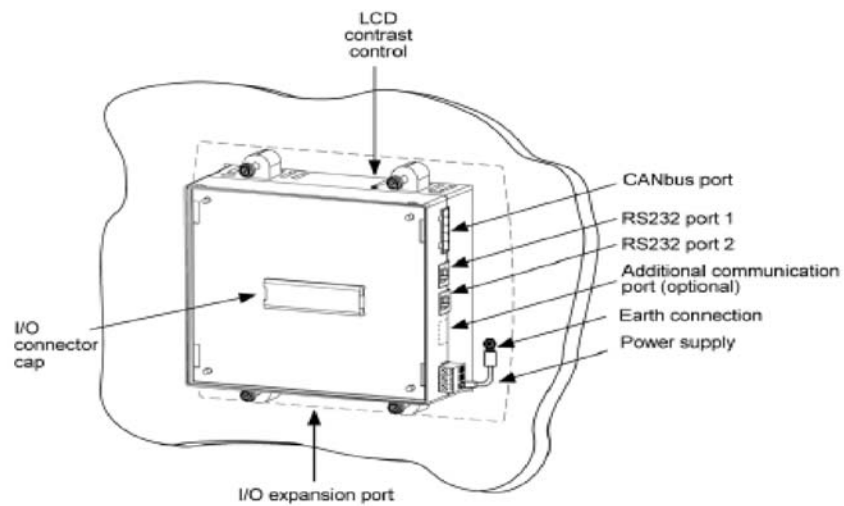

**Figure 2-4. Panel Mounted—Rear View**



## RS232 to RS422/RS485 Isolated Universal Converter

- The M90-19-R4 converts serial data from the RS232 standard to RS485.

### Features

- Universal converter:
  - must be used with the ModCon75 Controller
  - automatically senses the direction of the data flow, and switches the transmission direction
  - comes in a standard-sized housing, snap-mounts onto a 35 mm DIN rail
  - screw terminal block connections are provided
  - RJ11 connector provides easy plug-in connection for the ModCon75 Controller
  - supports networks containing up to 25 nodes
  - enables full or half-duplex communications
  - uses a stand-alone power supply
  - has LED indicators.

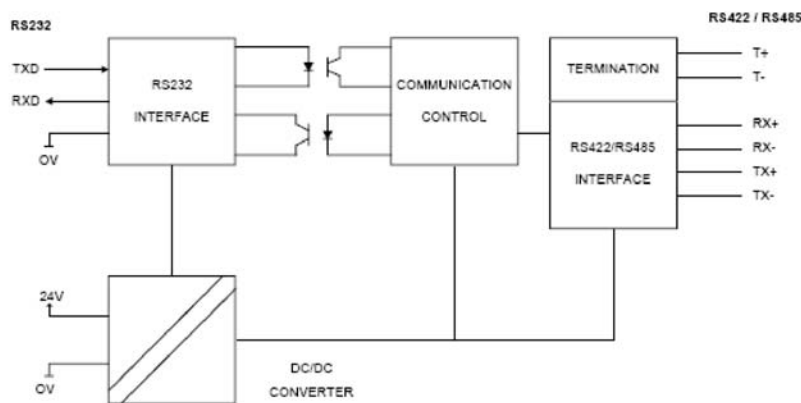

**Figure 2-5. Function Diagram**

## Wiring Connections

Read the following wiring considerations before making connections.

### Top Connectors

#### *Power Supply Terminals*

- Rear connector
- 24 V Supply voltage
- 0V Reference supply voltage
- Earth to ground

#### *RS232 Terminals*

- Front connector
- TXD RS232 transmit signal
- RXD RS232 receive signal
- 0V RS232 0V reference

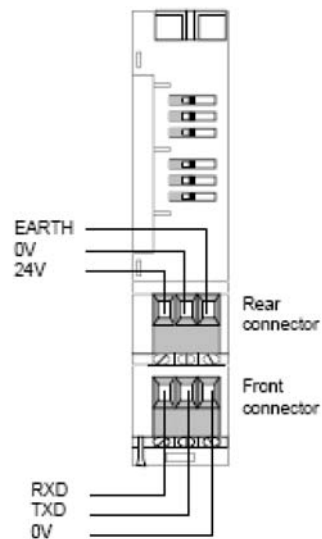
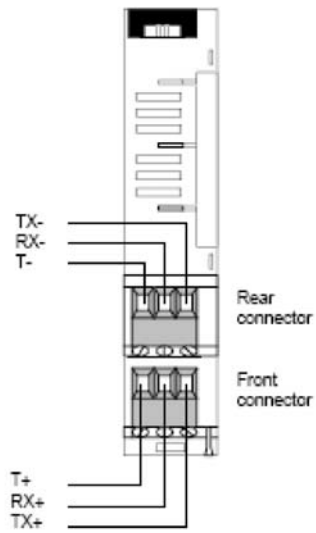

**Figure 2-6. Top Connectors**

## Bottom Connectors

### RS485 Terminals

- Rear connector
- TX- RS485 negative transmit signal
- RX- RS485 negative receive signal
- T- Negative termination
- Front connector
- TX+ RS485 positive transmit signal
- RX+ RS485 positive receive signal
- T+ Positive termination



**Figure 2-7. Bottom Connectors**

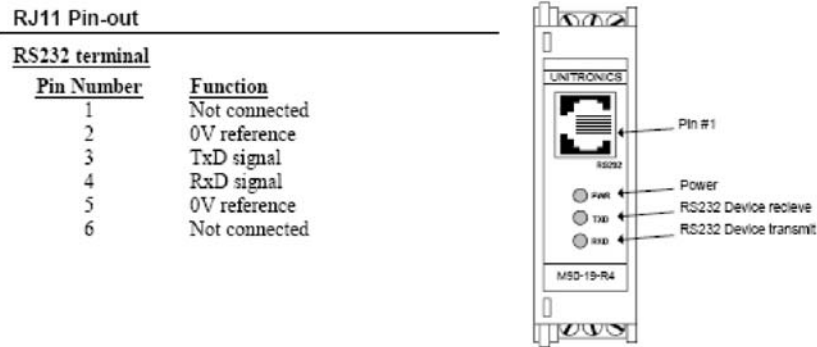

**Figure 2-8. R-J11 Pin-out**

### RS232 Wiring Considerations

- Since the RJ11 connector and the screw block terminal use the same signal source, only one can be used for establishing RS232 communications.
- Connect the screw block terminal as follows:
  - M90-19-R4 Device
    - RxD <----- TxD
    - TxD -----> RxD
    - 0V ----- 0V

### RS485 Wiring Considerations

- Use shielded, twisted pair cables.
- Configure the network as a multidrop bus network.
- Minimize the stub (drop) length leading from each device to the bus.
  - Ideally, the main cable should be run in and out of the networked device.
- Do not cross positive (A) and negative (B) signals.
  - Positive terminals must be wired to positive
  - Negative terminals must be wired to negative.

- Network termination points must be created by using the two end point devices integrated into your network.
  - Connect the T- terminal to Rx-, and T+ to RX+ in each end point device as shown in FIGURE 2-9.
- To support RS485, connect the Tx+ terminal to the Rx+, and the Rx- terminal to the Tx-, as shown in FIGURE 2-9.

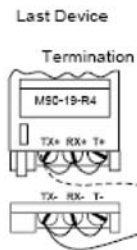

**Figure 2-9. RS485 Terminal Wiring**

## DIP Switch Settings

- The DIP switches:
  - are located on the top of the device
  - control:
    - Data format
    - transmission speed
    - whether communications are half or full duplex.
- Data can be transmitted in either 10- or 11-bit format.
  - Each format includes a start and stop bit.
- The DIP switches are shown in FIGURE 2-10.
  - a lowered switch is 'ON'
  - a raised switch is 'OFF'.

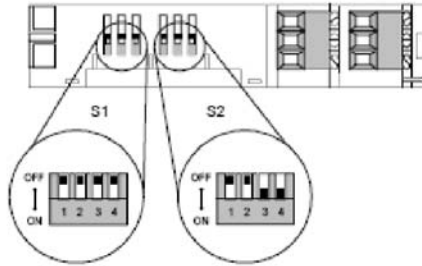

Dip Switch Setting							
S1				S2			
1	2	3	4	1	2	3	4
OFF	OFF	OFF	OFF	OFF	ON	OFF	ON

**Figure 2-10. Dip Switch Settings**

## Specifications

**Table 2-1. Specifications of RS232 to RS485 Isolated Universal Controller**

<b>POWER SUPPLY</b>	<b>Input Voltage</b>	24 VDC
	<b>Permissible Range</b>	20.4 to 28.8 VDC
	<b>Maximum Input Current</b>	35 mA @ 24 VDC
<b>RS232</b>	<b>Input voltage</b>	±20 VDC maximum
	<b>Cable Length</b>	15 m maximum (50 feet)
	<b>Interface Connectors</b>	RJ11 or screw-type, 2.5 mm, 2 terminal
<b>RS422/RS485</b>	<b>Input Voltage</b>	-7 to +12V differential maximum
	<b>Cable Type</b>	Shielded twisted pair, in compliance with EIA RS485
	<b>Cable Length</b>	1200m maximum (4000 feet)
	<b>Interface Connector</b>	Screw-type, 2.5 mm, 2 terminal
<b>GENERAL</b>	<b>Isolation</b>	yes
	<b>Size</b>	110.8 (L) x 22.5 (W) x 75 (H) mm [4.38 (L) x 0.89 (W) x 2.96 (H)"]

	<b>Weight</b>	98 g (3.44 oz)
	<b>Communication Status Indicators</b>	Yes
	<b>Baud Rate</b>	19200 bps
	<b>Mounting</b>	Snap-mounts onto 35mm DIN rail (EN50022-35)
	<b>Flame-Resistant</b>	UL94-VO
<b>ENVIRONMENTAL</b>	<b>Storage Temperature</b>	-20 to 70°C
	<b>Operating Temperature</b>	0 to 50°C
	<b>Storage Humidity</b>	10 to 95% relative humidity
	<b>Operating Humidity</b>	5 to 95% relative humidity

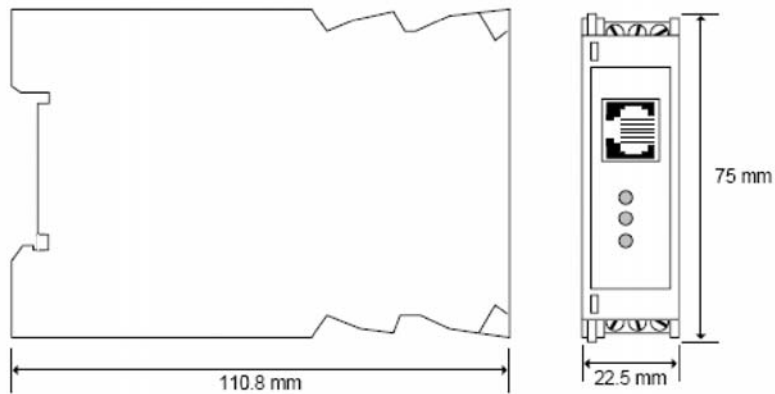

**Figure 2-11. Mechanical Dimensions**

## Chapter 3, Power Supply

- The controller requires an external 12- or 24-VDC power supply.
- The converter requires an external 24-VDC power supply
- The permissible input voltage range is 10.2 - 28.8 VDC, with less than 10% ripple.
- An external circuit protection device (FIGURE 3-1) must be used.
- **A non-isolated power supply can be used, provided that a 0 V signal is connected to the chassis.**

### Safety Considerations

#### **⚠ WARNING**

Do not touch live wires.

Standard safety considerations require that metal cabinet panels be earthed to avoid electrocution.

Do not connect either the 'Neutral' or 'Line' signal of the 110/220 VAC to the device's 0V pin.

In the event of voltage fluctuations or non-conformity to voltage power supply specifications, connect the device to a regulated power supply.

A technician or engineer trained in the local and national electrical standards must perform all tasks associated with the electrical wiring of the device.

Double-check all wiring before turning ON the power supply.

**FAILURE TO FOLLOW THE ABOVE CAN RESULT IN SERIOUS PERSONAL INJURY OR LOSS OF LIFE.**

### Wiring the Power Supply

- Do not use tin, solder, or any other substance on the stripped wire that might cause the wire strand to break.
- Install unit at maximum distance from high-voltage cables and power equipment.
- To avoid damaging the wire, do not exceed a maximum torque of 0.5 N•m (5 kgf•m).
- Use crimp terminals for wiring.
- Use 26-14 AWG wire for all wiring purposes.



1. Strip the wire to a length of  $7 \pm 0.5$  mm (0.250–0.300 inches).
2. Unscrew the terminal to its widest position before inserting a wire.
3. Insert the wire completely into the terminal to ensure a proper connection according to FIGURE 3-1.
4. Tighten enough to keep the wire from pulling free.

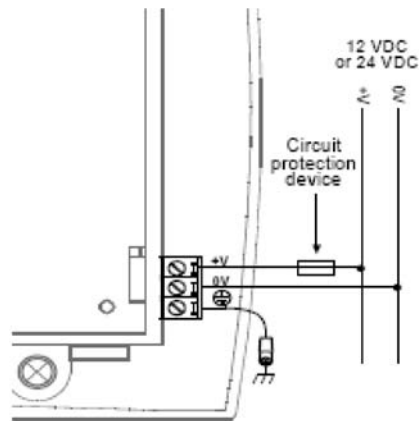

**Figure 3-1. Power Supply Wiring**

### **Earthing the Power Supply**

- To maximize system performance, avoid electromagnetic interference by:
  - mounting the controller on a metal panel
  - earthing the controller's power supply by:
    - connecting the chassis signal to the panel
    - connecting the tapered end to the power supply as shown in FIGURE 3-1.

**NOTE:** The wire used to earth the power supply must not exceed 8 cm in length. If your conditions do not permit this, do not earth the power supply.

## Chapter 4, I/O Modules

- The ModCon75 Controller is delivered with one Snap-in I/O Module installed at the factory. An optional Remote Relay Module is also available and is described in detail in Appendix C.

### Snap-in I/O Modules

- Snap-in I/O Modules provide a ModCon75 Controller with an on-board I/O configuration.
- The Snap-in I/O Module plugs directly into the back of the ModCon75 Controller, creating a self-contained control unit with a local I/O configuration.

### Features

- 16 isolated digital inputs, including two high-speed counter inputs, type pnp/npn (source/sink)
- 10 isolated relay outputs
- Four isolated pnp/npn (source/sink) transistor outputs
- Three analog inputs (not used in this application).

### **⚠ WARNING**

To avoid electric shock, turn OFF power to the unit before installing I/O modules.

## Installing a Snap-in I/O Module

- Snap-in I/O Modules can be installed before or after mounting the unit.
  - The protective cap covering the I/O connector on the back of the controller:
    - must cover the connector when a Snap-in I/O Module is *not* attached to the controller
    - must be removed before installing a module.
1. Pry off the cap with a screwdriver.
  2. Line up the ModCon75 Controller circular guidelines with the Snap-in I/O Module guidelines (FIGURE 4-1).

3. Apply even pressure on all four corners until you hear a distinct 'click'.
4. Check that all sides and corners are correctly aligned.
  - The module is now installed.

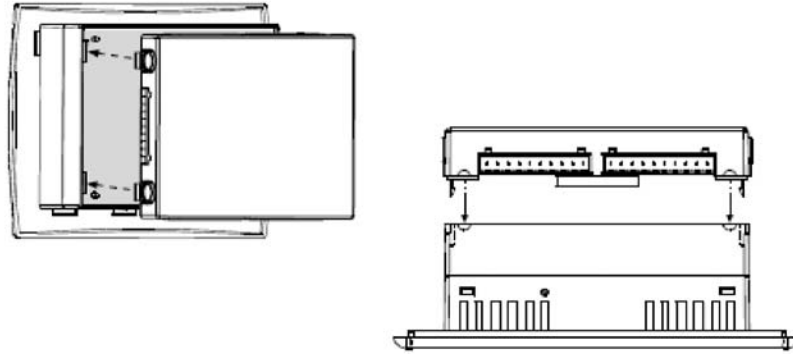

*Figure 4-1. Installing a Snap-in I/O Module*

## Removing a Snap-in I/O Module

1. Press and hold down the buttons on the sides of the module to open the locking mechanism.
2. Gently rock the module from side to side, easing the module from the controller.
3. Replace the protective cap on the connector.

## User Safety and Equipment Protection Guidelines

- Dispose of this product in accordance with local and national standards and regulations.
- Only qualified service personnel should open this device or perform repairs.
- This document is intended to aid trained and competent personnel in the installation of this equipment as defined by the European directives for machinery, low voltage, and EMC. Only a technician or engineer trained in the local and national electrical standards should perform tasks associated with the device's electrical wiring.

## **⚠ WARNING**

**Failure to comply with appropriate safety guidelines can result in severe personal injury or property damage. Always exercise proper caution when working with electrical equipment.**

- Check the user program before running it.
- Do not attempt to use this device with parameters that exceed permissible levels.
- Install an external circuit breaker and take appropriate safety measures against short-circuiting in external wiring.
- To avoid damaging the system, do not connect or disconnect the device when the power is ON.
- Ensure that terminal blocks are properly secured in place.

### **Environmental Considerations**

- Do not install the unit in areas with:
  - excessive or conductive dust
  - corrosive or flammable gas
  - moisture or rain
  - excessive heat
  - regular impact shocks
  - excessive vibration.
- Provide proper ventilation by leaving at least 10 mm of space between the top and bottom edges of the device and the enclosure walls.
- Do not place in water or let water leak onto the unit.
- Do not allow debris to fall inside the unit during installation.

### **Wiring**

- Do not touch live wires.
- Unused pins should not be connected. Ignoring this directive may damage the device.
- Do not connect the 'Neutral' or 'Line' signal of the 110/220 VAC to the device's 0 volt pin.
- Double-check all wiring before turning ON the power supply.

### Wiring Procedures

- Use crimp terminals for wiring.
  - Use 26-12 AWG wire (0.13 mm<sup>2</sup>–3.31 mm<sup>2</sup>) for all wiring.
1. Strip the wire to a length of 7 ±0.5mm (0.250–0.300 inches).
  2. Unscrew the terminal to its widest position before inserting a wire.
  3. Insert the wire completely into the terminal to ensure that a proper connection can be made.
  4. Tighten enough to keep the wire from pulling free.

#### **⚠ CAUTION**

To avoid damaging the wire, do not exceed a maximum torque of 0.5 N•m (5 kgf•m).

Do not use tin, solder, or any other substance on stripped wire that might cause the wire strand to break.

Install at maximum distance from high-voltage cables and power equipment.

### I/O Wiring—General

- Input or output cables should not:
  - be run through the same multi-core cable
  - share the same wire.
- Allow for voltage drop and noise interference with input lines used over an extended distance.
- Use wire that is properly sized for the load.

### Digital Inputs

- Each group of eight inputs:
  - has a common signal
  - can be used as pnp (source) or npn (sink) when appropriately wired as shown in FIGURE 4-2.
- Inputs I0 through I8 can be used to reset a latched zone relay.
- Input I11 can be used to reset a latched relay on a remote sensor.
- Input I12 can be used as a remote reset for the horn relay.

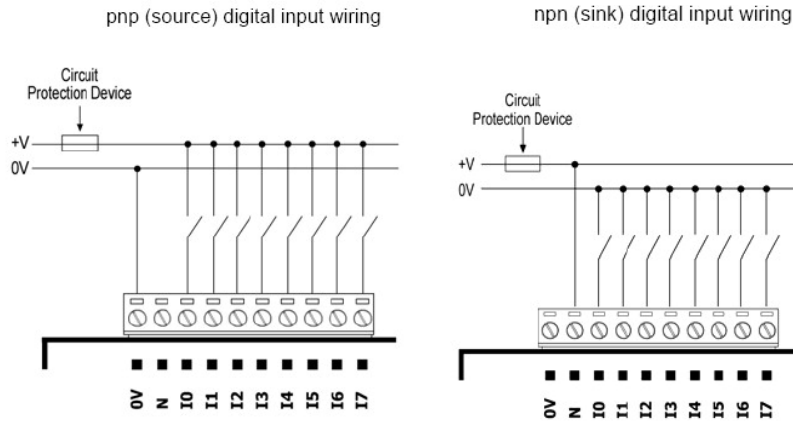

I0	Unlatch Zone 1	I6	Unlatch Zone
I1	Unlatch Zone 27	I7	Unlatch Zone 8
I2	Unlatch Zone 3	I8	Unlatch Zone 9
I3	Unlatch Zone 4	I11	Remote Sensor Acknowledge
I4	Unlatch Zone 5	I12	External Horn Silence
I5	Unlatch Zone 6		

**Figure 4-2. Digital Inputs Used as pnp (Source)**

## Digital Outputs

### Wiring Power Supplies

1. Connect the "positive" lead to the:
  - "V1" terminal for the relay outputs
  - "V2" terminal for the transistor outputs.
2. In both cases, connect the "negative" lead to the "0V" terminal for each output group.
  - In the event of voltage fluctuations or non-conformity to voltage power supply specifications, connect the device to a regulated power supply.
  - Do not connect the 'Neutral' or 'Line' signal of the 110/220 VAC to the device's 0V pin.

### Relay Outputs

- The relay output 0-volt signal is isolated from the controller 0-volt signal.

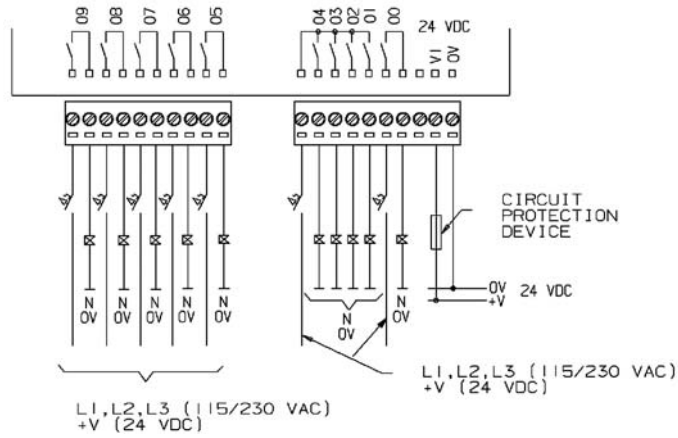

O0	Zone 1 Alarm	O5	Zone 6 Alarm
O1	Zone 2 Alarm	O6	Zone 7 Alarm
O2	Zone 3 Alarm	O7	Zone 8 Alarm
O3	Zone 4 Alarm	O8	Zone 9 Alarm
O4	Zone 5 Alarm	O9	Horn Relay

**Figure 4-3. Relay Outputs**

### Increasing Contact Life Span

To increase the life span of the relay output contacts and protect the device from potential damage by reverse EMF, connect:

- a clamping diode in parallel with each inductive DC load
- an RC snubber circuit in parallel with each inductive AC load.

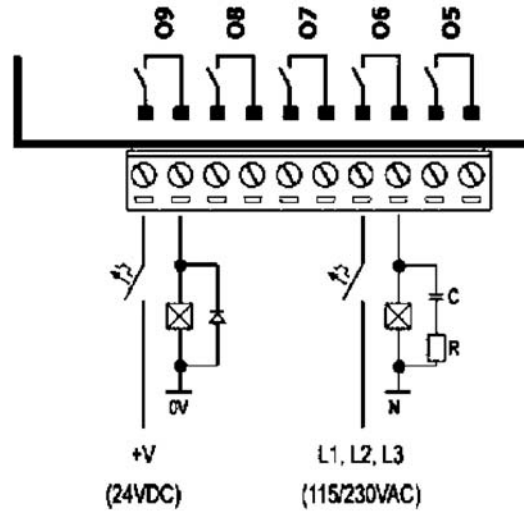

**Figure 4-4. Increasing Contact Life Span**

### Transistor Outputs

- Each output can be wired separately as either npn or pnp.
- The 0-volt signal of the transistor outputs is isolated from the controller's 0-volt signal.
- The ModCon75 Controller application uses transistor output O11 for FAULT indication.

NOTE: The FAULT indication is normally energized and is deactivated when a fault occurs.

- The ModCon75 Controller application uses O12 for an internal timer which toggles at a rate of 0.5 seconds ON and 0.5 seconds OFF (1 Hz.). This can be used for external monitoring of the controller operational status.



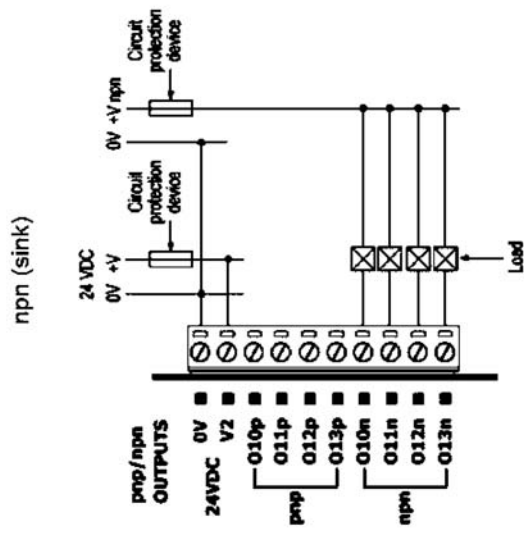
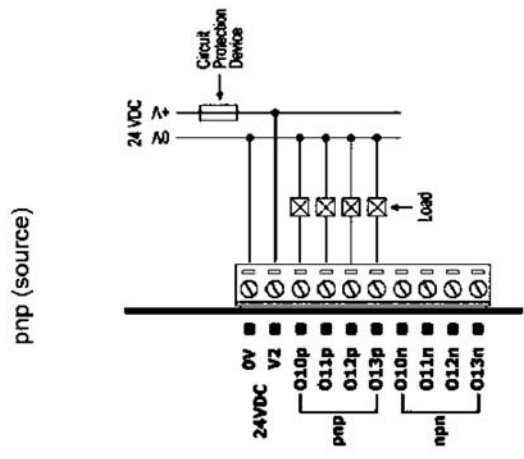

Figure 4-5. Transistor Outputs

**Table 4-1. Snap-in I/O Module Technical Specifications**

<b>DIGITAL INPUTS</b>	<b>Number of Inputs</b>	16 (in two groups)
	<b>Input Type</b>	pnp (source) or npn (sink), set by wiring
	<b>Galvanic Isolation</b>	Yes
	<b>Nominal Input Voltage</b>	24 VDC
	<b>Input Voltage</b>	pnp (source) 0-5 VDC for Logic '0'
		17-28.8 VDC for Logic '1'
		npn (sink) 17-28.8 VDC for Logic '0'
	<b>Input Current</b>	0-5 VDC for Logic '1'
		6 mA @ 24 VDC for inputs #4 to #15 8.8 mA @ 24 VDC for inputs #0 to #3
	<b>Response Time</b>	10 mSec typical
<i>High speed input Specifications below apply when these inputs are wired for use as a high-speed counter input/shaft encoder.</i>		
<b>Resolution</b>	32-bit	
<b>Frequency</b>	10 kHz maximum	
<b>Minimum Pulse Width</b>	40 $\mu$ s	
<b>RELAY OUTPUTS</b>	<b>Number of Outputs</b>	10 (See NOTE 3)
	<b>Output Type</b>	Normally de-energized SPST-NO relay; 230 VAC / 24 VDC
	<b>Type of Relay</b>	Takamisawa (Fujitsu) JY-24H-K or NAIS (Matsushita) JQ1AP-24V or OMRON G6B-1114P-24VDC
	<b>Galvanic Isolation</b>	Yes
	<b>Output Current</b>	Resistive Load
		5 A maximum per output
	<b>Inductive Load</b>	8 A maximum total for common (See NOTE 1)
		1 A maximum per output
		4 A maximum total for common (See NOTE 3)
	<b>Maximum Frequency</b>	10 Hz
	<b>Contact Protection</b>	External precautions required (see Increasing Contact Life Span)
	<b>Output Power Supply Nominal Operating Voltage</b>	24 VDC
	<b>Operating Voltage</b>	20.4 to 28.8 VDC

	<b>Maximum Current Consumption</b>	90 mA @ 24 VDC	
<b>NOTE 1.</b> Outputs #1, #2, #3, and #4 share a common signal. All other outputs have individual contacts.			
<b>TRANSISTOR OUTPUTS</b>	<b>Number of Outputs</b>	4; each can be individually wired as pnp (source) or npn (sink)	
	<b>Output Type</b>	<b>pnp</b> P-MOSFET (open drain) <b>nnp</b> open collector	
	<b>Galvanic Isolation</b>	Yes	
	<b>Output Current</b>	<b>pnp</b>	0.5 Amp max (per output) Total current: 2 A max (per group)
		<b>nnp</b>	50 mA max (per output) Total current: 150 mA (per group)
	<b>Maximum Frequency</b>	<b>Resistive Load</b>	20 Hz
		<b>Inductive Load</b>	0.5 Hz
	<b>ON Voltage Drop</b>	<b>pnp</b>	0.5 VDC max
		<b>nnp</b>	0.85 VDC max
	<b>Short Circuit Protection</b>	Yes (pnp only)	
<b>Power Supply Operating Voltage</b>	20.4 to 28.8 VDC		
<b>Power Supply Nominal Operating Voltage</b>	24 VDC		
<b>nnp (sink) Power Supply Operating Voltage</b>	3.5 V to 28.8 VDC (unrelated to Remote Relay Module voltage or Controller voltage)		
<b>ENVIRONMENTAL</b>	<b>Operating Temperature</b>	0 to 50°C (32 to 122°F) -	
	<b>Storage Temperature</b>	-20 to 60°C (-4to 140°F)	
	<b>Relative Humidity (RH)</b>	5% to 95% (non-condensing)	
	<b>Dimensions</b>	138 W x 23 H x 123 mm D (5.43 W x 0.9 H x 4.84" D)	
	<b>Weight</b>	222 g (7.8 oz)	

## Chapter 5, Communications

- This chapter contains guidelines for communications connections.
- All ModCon75 Controllers contain two RS232 ports and an RS485.

### RS232

- The RS232 serial ports are used for:
  - Downloading programs from a PC by authorized MSA Service Representative
  - Communicating to the RS232 to RS485 converter, which communicates to the Ultima X3 units.
- The RS232 interface is via RJ-11 type serial ports located on the side of the controller.

NOTE: Turn OFF power before making communications connections.

**NOTE: Do not connect the controller directly to a telephone or telephone line.**

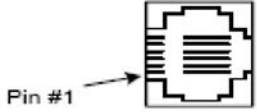
Diagram	Pin Number	Function
	1	DTR signal*
	2	0V reference
	3	TxD signal
	4	RxD signal
	5	0V reference
	6	DSR signal*

*\*Standard programming cables do not provide connection points for pins 1 and 6.*

**Figure 5-1. RS232 Port Printout**

- Signals are related to the controller's 0V; this is the same 0V used by the power supply.
- The RJ-11 type serial port located on the side of the controller must always be used with an appropriate adapter.
- The RS232 serial port is not isolated.

## Chapter 6, Operating Instructions

### Power up Screen

- This screen appears when power is applied to the ModCon75 Controller.



**Figure 6-1. Power-up Screen**

## Main Menu Screen



**Figure 6-2. Main Menu Screen**

**Table 6-1. Keypad Functions**

KEYPAD KEY	FUNCTION
F1	Add Units: Add Ultima X <sup>3</sup> transmitters to the network
F2	Add Unit Setpoints: Sets Alarms: Enable/disable, increasing/decreasing, latching/non-latching, set point values, and zone control relays
F3	Main Data Screen: Display all units on network or a specific node
F4	Displays set-points (view only - all alarm settings)
F5	Password Editor: Two password levels: MSA Default and User programmable (default = 0)
F6	Modbus Alarms: Displays communication status
F7	Sensor Fault: Automatically appears if Ultima X <sup>3</sup> transmitter enters a fault condition
F8	Zones Editor: Zone relays can be configured for latch/unlatch, OFF/ON delay and delays of up to 15 minutes
F9	Remote I/O Editor: Activate only when optional remote relay modules are on the network
F10	Network Settings

NOTE: To make selection, press desired function key

## F1-Add Units to Network

- Password protected; see FIGURE 6-3
- Password is two levels:
  - Level 1 is factory default  
(contact an MSA Service Representative if needed)
  - Level 2 is user-configurable (Default = 0).



**Figure 6-3. Password Entry**

- (FIGURE 6-4) Use this screen to:
  - initialize a new Ultima X<sup>3</sup> sensor or
  - read all units on the network.

F14- Select F14 once the following three steps are completed:

- 1) all Ultima X<sup>3</sup> sensors (up to 25 X<sup>3</sup> transmitters with up to three sensors each) are wired to the network and have unique IDs.
- 2) network IDs are set by the Ultima Controller (P/N 809086)  
(Valid IDs are 2 - 26).

NOTE: ID 0 is the broadcast modbus message; ID 1 is the ModCon75 address.

- 3) Baud rate = 19200 and Parity = even.
  - This process may take several minutes.





**Figure 6-4. Add Units to the Network**

- F14      Populate registry
- F15      Stop ping
- F6        View registry list
- F13      Keep old setpoints
- Press ESC- to go back to Main Menu Screen or F6 to view results.

NOTE: If changes are made to individual X<sup>3</sup> units through the use of the Ultima Controller, user must run F14 to repopulate the registry. Populating the registry will change the setpoints in the ModCon75 Controller to match the setpoints and configuration of all sensors on the network.

## Screen Displaying Node IDs Found

- F6- Displays all unit IDs found on the network (FIGURE 6-5).
- Press ► key to view other units in register list.



**Figure 6-5. Node IDs Found**

NOTE: Verify that the ModCon75 Controller found all Ultima X<sup>3</sup> units on the network. If the total number is less than the actual number on the network, check your wiring and make sure that each X<sup>3</sup> on the network has its own unique address in the range of 2 through 26.

## F2-Add Unit Setpoints

- Accesses the screen showing Current Setpoint values read from the Ultima X3 unit (FIGURE 6-6).



**Figure 6-6. Allows Users to Set Enabled or Disabled Alarms**

- Cursor flashes at the network ID#:
- Enter the Unit ID for the Setpoints and alarm functions to be modified and press enter ↵.
  - The current settings for the selected unit or ID appear.
  - To modify a setting, press the appropriate function key:
    - When all desired changes are made, press F6 to advance to the next settings screen.

Repeat this procedure for other sensor option screens (FIGURES 6-7 and 6-8).

### **⚠ WARNING**

If the user changes a sensor, the ModCon75 Controller will retain the setpoints of the previous sensor. To upload new setpoints, the user must populate the sensors through the F1 menu option. Improper setpoints can result in exposure to hazardous atmospheres.

(see "F1-Add Units to the Network" earlier in this chapter).



**Figure 6-7. Allows Users to Set Increasing or Decreasing Alarms**



**Figure 6-8. Allows users to Set Latching / Non-latching Alarms**

NOTE: User must wait for the controller to move to the next screen; this will take six seconds.

This Latching Function only changes the relay operation of the Ultima X<sup>3</sup> unit. For latching an alarm on the ModCon75 Controller, use a Zone relay and program it for latching.

A latched relay at the Ultima X3 unit may be cleared at the ModCon75 Controller by pressing the down arrow (▼) key.



**Figure 6-9. Allows Users to Assign Zone Control Relays to Caution, Warning and Alarm Setpoints for Sensors 1, 2, and 3**

- Press F6 to skip to the next screen or ENTER to change Zone Relays.
  - Numbers correspond to relays on back of unit.
 

Output O0=Zone 1	Output O5=Zone 6
Output O1=Zone 2	Output O5=Zone 6
Output O2=Zone 3	Output O7=Zone 8
Output O3=Zone 4	Output O8= Zone 9
Output O4=Zone 5	Output O9=Horn Relay
  - The Horn relay- Output (O9):
    - is used for remote alarms
    - sounds a horn on any caution, warning, or alarm condition.
  - Silence of Horn is accomplished by connecting a push-button to (I12) terminals and/or by pressing the +/- button located on the front panel.



**Figure 6-10. Current Set-point values Read from the Selected Ultima X<sup>3</sup> Unit**

- Pressing ESC- returns the user to the main menu screen and does not change saved setpoints
- Pressing ENTER- advances to the screen for changing the Set-point values.
  - The screen will display Current Values for Unit # for Sensor 1 presets



**Figure 6-11. Sensor 1 Preset Screen**

- ENTER enables user to change presets.

NOTE: Do not use decimal points; the Decimal is fixed; therefore, to enter 19.5:

- Press ENTER
- Type 19 and ENTER
- Type 5 and ENTER.

- F6 will skip to sensor 2 presets screen (FIGURE 6-12)



**Figure 6-12. Sensor 2 Preset Screen**

- F6- Skips to next screen
- ENTER- Changes presets (see NOTE above)



**Figure 6-13. Sensor 3 Preset Screen**

- F6- Skips to next screen
- ENTER- Changes presets

NOTE: The ModCon75 Controller displays to one decimal point. With certain sensors (ClO<sub>2</sub>, CO<sub>2</sub>, etc.), alarm setpoints in the Ultima X3 unit may be represented to two decimal points. In this

instance, the ModCon75 Controller will round to the nearest single decimal.



**Figure 6-14. Displays all Presets before Downloading to the Unit**

- F7:
  - Sends all changes to the ModCon75 Controller
  - Sets Controller relays (connections located on back of unit) to activate according to caution, warning or alarm settings set on the Choose Zone event screen
  - Verifies that all values were sent successfully.

NOTE: If user does not press F7, the changes will not be made.  
Combustible sensors cannot be set to a range of 61-100.





**Figure 6-15. Verification Screen**

- ESC-to return to the Main screen

NOTE: If changes are made to individual X<sup>3</sup> units through the use of the Ultima Controller, user must run F14 to populate the registry. Populating the registry will change the setpoints in the ModCon75 Controller to match the setpoints and configuration of all sensors on the network.

**⚠ WARNING**

**Failure to follow the above instructions can result in the ModCon75 Controller not properly indicating a sensor alarm/fault condition.**

## F3-Main Data Screen



**Figure 6-16. Main Data Screen**

- F1- Scrolls through all units on the Modbus network.
- F2- Allows one to view a specific unit.
- F3- Adjusts the scroll time reading each node.

Typical Display shows three sensors on the ModCon 75 Controller.

- "All Clear" - shows all three sensors are not in alarm.
- Box in lower-right corner shows ModBus network/sensor status.
- Current values are shown next to sensor number.



**Figure 6-17. All Clear Status Screen**

- ESC-Back to Main screen

### F4-Display Setpoints (view only)

- Screen does not allow changing presets.



**Figure 6-18. Display Only Setpoints**

- ⇒ Accesses screen showing presets for Sensor 1.

## F5- Password Editor

- F1- Password Default is MSA default password.
- F2- Default Password is 0.
  - User can change this password to protect against unauthorized changes.



*Figure 6-19. Password Editor*

## F6- Modbus Alarms

- Screen shows Modbus failures and identifies failed unit (node) #.
- Fault screen will stay active after five minutes and then return to the Main Menu screen. User can also press ESC to return to the Main Menu screen.



**Figure 6-20. Modbus Alarms**

## F7- Fault Status

- Example of Diagnostic screen Identifying Unit ID and actual fault on unit ID
- Fault screen will stay active after five minutes and then return to the Main Menu screen. User can also press ESC to return to the Main Menu screen.



**Figure 6-21. Fault Status**

- The ModCon 75 will display the following Ultima X3 sensor faults:
  - + LOC
  - Over-range
  - Quick under-range
  - Under-range
  - Sensor missing
  - Sensor End of Life
  - Calibration fault
  - Power Fail fault
  - Configuration reset
- All other faults are shown as General Fault

## F8- Zone Editor

- The specific zone is selected under F2 - Add Setpoints.
- This screen enables user to program zone relays for a latched or unlatched function.
  - If latched function is selected, relay is unlatched by supplying a closed contact to the corresponding input or by pressing the up arrow (▲) key.

I0- Unlatch Zone 1

I1- Unlatch Zone 2

I2- Unlatch Zone 3

I3- Unlatch Zone 4

I4- Unlatch Zone 5

I5- Unlatch Zone 6

I6- Unlatch Zone 7

I7- Unlatch Zone 8

I8- Unlatch Zone 9

I11 -Ultima X3 monitor  
acknowledge

I12- Horn silence



**Figure 6-22. Zone Editor - Set Relays as Latched or Unlatched**

- F6- Skips to next screen
- When zone relays are set as unlatched, then Zone relays can be set to On-Delay or Off-Delay.
  - On-Delay: relay activates only if alarm exists for the set time.
  - Off-Delay (Typically used for fan control): relay stays energized for the set delay time after the alarm condition clears.

NOTE: Selecting latching disables ON delay, OFF delay, and delay time settings.

Times are adjustable from 0 seconds to 15 minutes.

After entering time delay, press enter ↵ for data to display.

**⚠ WARNING**

Do not use On-Delay for any safety critical function. Use only for Process control. Failure to follow the above can result in personal injury or loss of life.

**F9- Remote Relay Editor  
(Optional: Requires Remote Relay Modules)**



**Figure 6-23. Remote Relay Editor**

Enter 30 if only one remote relay is on the network, 31, for two remote relays, 32 for three remote relays and 33 for four remote relays. To activate or Deactivate remote relays, enter F2 to Enable or Disable.

**Optional: Remote Relay units**

A total of four remote relay units may be added to the modbus network (see Appendix C for additional details). Modbus ID numbers of the remote relay modules must be programmed for ID#30, 31, 32 or 33.

Input Remote Relay on all remote units is the local silence alarm. Closing this input will silence the local alarm as well as the ModCon75 Alarm. Output O0 is for the local alarm output.

Note: If Zone Alarms are programmed as Latch, one can silence the alarm at the remote relay, but the Zone alarm will not be cleared until the unlatch input is initiated at the ModCon75 Controller.

Following would be used for remote alarms:



- ID#30 Output O0- Local horn output  
Output O1- Zone 1 Alarm  
Output O2-Zone 2 Alarm  
Input I0- Local area silence
- ID#31 Output O0- Local horn output  
Output O1- Zone 3 Alarm  
Output O2- Zone 4 Alarm  
Input I0- Local area silence
- ID#32 Output O0- Local horn output  
Output O1- Zone 5 Alarm  
Output O2- Zone 6 Alarm  
Input I0- Local area silence
- ID#33 Output O0- Local horn output  
Output O1- Zone 7 Alarm  
Output O2- Zone 8 Alarm  
Input I0- Local area silence

Example: Program ID# 5 sensor 1 caution alarm to zone 1. Therefore, if Sensor 1 caution alarm occurs, this will trip the ModCon75 Zone 1 output (O0) as well as the remote relay module ID#30, output O1.

### F10- Network Settings

- For Ethernet capability, enter IP Address, Subnet Mask and Default Gateway information.



**Figure 6-24. F10- Network Settings**

## Chapter 7, Operating Panel Options

The operating panel can be customized by:

- Adjusting the contrast of the LCD screen.
- Labeling the keypad keys.

### Adjusting the LCD Screen Contrast

To adjust the screen contrast:

1. Locate the LCD Contrast control on the top of the controller, shown in FIGURE 2-4.
2. Using a flat-bladed screwdriver, turn the control in either direction to change the screen contrast.

### Labeling Keys

- Most controller keys can be labeled:
  1. Before mounting the controller, insert keypad slides into the slots under the cover of the operating panel.
    - Keypad slides are strips of plastic cut to fit under specific groups of keys.
  2. Write/print text onto a slide and insert in the appropriate slot.
    - Text should be visible through the operating panel covering.
    - A special slide is provided to allow the user to display a picture (e.g., company logo or a system symbol).
    - Slides cannot be inserted under the following keys:
      - directional arrow keys
      - ESC key
      - <i> key.

- The controller is shipped with two sets of slides appropriate for the user's controller model:
  - One set of slides is already inserted into the operating panel
  - The other set does not include a picture slide and is packaged separately.

### **Printing Customized Slides Using Templates**

- Slides can also be created by using Visio and Word stencils designed for the user's controller model.
  - The resulting slides can be printed on film and cut to size.

### **Labeling Slides**

- Slides can be labeled with a fine-tip permanent marker or professional labeling tool.

### **Removing and Inserting Slides**

- To access slides, move the rubber seal seated in back of the operating panel.

#### **⚠ CAUTION**

**Slides fit tightly into the operating panel slots to keep the label over the correct key. Avoid use of excessive force when removing or inserting slides in order not to damage the slides.**

### **Removing a Slide**

- Slides have tabs to allow for easy removal.
  1. Grasp the tab with fingers or flat-bladed long-nose pliers.
  2. Pull gently and steadily until the slide slowly slips out.

### **Inserting a Slide**

- Gently and steadily slip the slide into the slot.

## Chapter 8, Technical Specifications

**Table 8-1. ModCon75 Specifications**

<b>POWER SUPPLY</b>	<b>Input Voltage</b>	12 or 24 VDC for controller 24 VDC for RS232 to RS485 converter
<b>PERMISSIBLE RANGE</b>		10.2 to 28.8 VDC with less than 10% ripple
<b>V260</b>	<b>Maximum Current</b>	460 mA @ 12 VDC 220 mA @ 24 VDC
	<b>Typical Power Consumption</b>	4.2 W
<b>BATTERY BACK-UP</b>		7-year typical battery back-up for real-time clock (RTC) and all system data, including variable data
<b>GRAPHIC DISPLAY</b>	<b>ModCon75 Controller</b>	Type STN LCD Negative blue STN LCD Graphic B & W FSTN LCD
	<b>Illumination backlight LED</b>	yellow-green CCFL (fluorescent lamp)
	<b>Display Resolution</b>	128 x 64 pixels, 240 x 64 pixels, 320 x 240 pixels (QVGA)
<b>KEYPAD</b>		24 Number of Keys 33 27, including soft keys and alphanumeric keypad
	<b>Key Type</b>	Metal dome, sealed membrane
	<b>Slides</b>	Provided for picture, alphanumeric keypad and FUNCTION keys
<b>COMMUNICATION</b>	<b>RS232</b>	2 ports
	<b>Isolation</b>	No
	<b>Voltage Limits</b>	20 V
	<b>RS485</b>	1 port, via converter
	<b>Isolation</b>	No
	<b>Ultima X3 Nodes</b>	Up to 25
<b>DIMENSIONS</b>	<b>Size</b>	See FIGURE 8-1
<b>WEIGHT</b>		429g (15.1 oz) 695g (24.5 oz) 860g (30.4 oz)
<b>MOUNTING</b>	<b>Panel-Mounting</b>	See FIGURE 8-1
<b>ENVIRONMENT</b>	<b>Panel Mounted</b>	IP65 / NEMA4X (front panel)
	<b>Operational Temperature</b>	0 to 50°C (32 to 122°F)
	<b>Storage Temperature</b>	-20 to 60°C (-4 to 140°F)
	<b>Relative Humidity</b>	5% to 95% (non-condensing)
<b>ACCESSORIES</b>	<b>Programming Cable</b>	3-pin power supply connector
		Mounting brackets (x4)
		Spare set of slides

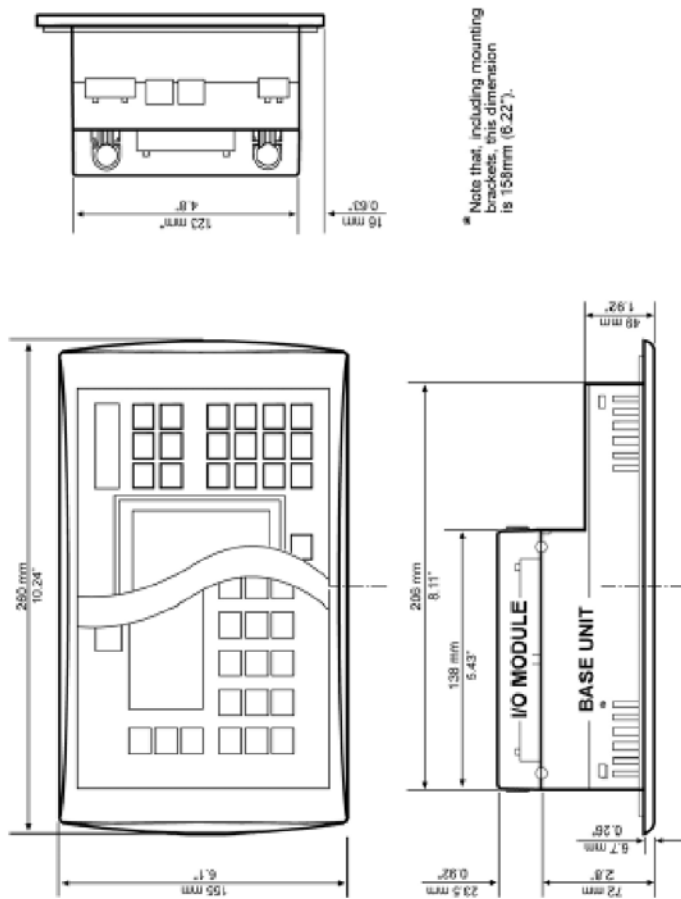

**Figure 8-1. Dimensions**

## Appendix A, Port 3 Ethernet Port / OPC Server

- This device has the capability to communicate to third party HMI packages, such as Wonderware, Intellution, etc.
- Communication is done through the ethernet board, which is located on the ModCon75 Controller port 3 location.
- Communication is ModBus over ethernet.
- One can communicate through the OPC server (available as a download on <http://www.unitronics.com/download.htm>) or through an ethernet server provided by the third party vendor.
- Using the OPC server, the following will apply:
  - Mapping of variables:
    - Name = Modcon75
    - IP Address = 192.168.1.11
    - Subnet Mask = 255.255.255.0
    - Gateway = 192.168.1.254
  - Retrieving gas value for specific sensor:

Value is split into two registries;  
For example, ID#2 sensor #1:

    - MI300 provides value to the left of the decimal point
    - MI325 provides value to the right of the decimal point.

(See Appendix B, "Memory Integers").
- When using the ethernet server (provided by the third party vendor), the addressing may be off-set by one.

## Appendix B, Register Maps

### WARNING

Do Not write-to or alter the ModCon 75 registers. Doing so can affect proper operation of the controller. The following register maps are provided for read-only use.

#### CRITICAL MEMORY BITS

10	ModBus Comm Failure
194	Acknowledge Alarm
261	Sensor 1 Calibration Active
262	Sensor 2 Calibration Active
263	Sensor 3 Calibration Active
670	Zone 1 Alarm
671	Zone 2 Alarm
672	Zone 3 Alarm
673	Zone 4 Alarm
674	Zone 5 Alarm
675	Zone 6 Alarm
676	Zone 7 Alarm
677	Zone 8 Alarm
678	Zone 9 Alarm

#### MEMORY INTEGERS

273	DEC ID #2 Fault status message number
274	DEC ID #3 Fault status message number
275	DEC ID #4 Fault status message number
276	DEC ID #5 Fault status message number
277	DEC ID #6 Fault status message number
278	DEC ID #7 Fault status message number
279	DEC ID #8 Fault status message number
280	DEC ID #9 Fault status message number
281	DEC ID #10 Fault status message number
282	DEC ID #11 Fault status message number
283	DEC ID #12 Fault status message number
284	DEC ID #13 Fault status message number
285	DEC ID #14 Fault status message number
286	DEC ID #15 Fault status message number
287	DEC ID #16 Fault status message number
288	DEC ID #17 Fault status message number
289	DEC ID #18 Fault status message number

290	DEC ID #19 Fault status message number
291	DEC ID #20 Fault status message number
292	DEC ID #21 Fault status message number
293	DEC ID #22 Fault status message number
294	DEC ID #23 Fault status message number
295	DEC ID #24 Fault status message number
296	DEC ID #25 Fault status message number
297	DEC ID #26 Fault status message number
300	DEC ID #2 Sensor 1 A
301	DEC ID #3 Sensor 1 A
302	DEC ID #4 Sensor 1 A
303	DEC ID #5 Sensor 1 A
304	DEC ID #6 Sensor 1 A
305	DEC ID #7 Sensor 1 A
306	DEC ID #8 Sensor 1 A
307	DEC ID #9 Sensor 1 A
308	DEC ID #10 Sensor 1 A
309	DEC ID #11 Sensor 1 A
310	DEC ID #12 Sensor 1 A
311	DEC ID #13 Sensor 1 A
312	DEC ID #14 Sensor 1 A
313	DEC ID #15 Sensor 1 A
314	DEC ID #16 Sensor 1 A
315	DEC ID #17 Sensor 1 A
316	DEC ID #18 Sensor 1 A
317	DEC ID #19 Sensor 1 A
318	DEC ID #20 Sensor 1 A
319	DEC ID #21 Sensor 1 A
320	DEC ID #22 Sensor 1 A
321	DEC ID #23 Sensor 1 A
322	DEC ID #24 Sensor 1 A
323	DEC ID #25 Sensor 1 A
324	DEC ID #26 Sensor 1 A
325	DEC ID #2 Sensor 1 B
326	DEC ID #3 Sensor 1 B
327	DEC ID #4 Sensor 1 B
328	DEC ID #5 Sensor 1 B
329	DEC ID #6 Sensor 1 B
330	DEC ID #7 Sensor 1 B
331	DEC ID #8 Sensor 1 B
332	DEC ID #9 Sensor 1 B
333	DEC ID #10 Sensor 1 B



334	DEC ID #11 Sensor 1 B
335	DEC ID #12 Sensor 1 B
336	DEC ID #13 Sensor 1 B
337	DEC ID #14 Sensor 1 B
338	DEC ID #15 Sensor 1 B
339	DEC ID #16 Sensor 1 B
340	DEC ID #17 Sensor 1 B
341	DEC ID #18 Sensor 1 B
342	DEC ID #19 Sensor 1 B
343	DEC ID #20 Sensor 1 B
344	DEC ID #21 Sensor 1 B
345	DEC ID #22 Sensor 1 B
346	DEC ID #23 Sensor 1 B
347	DEC ID #24 Sensor 1 B
348	DEC ID #25 Sensor 1 B
349	DEC ID #26 Sensor 1 B
350	DEC ID #2 Sensor 2 A
351	DEC ID #3 Sensor 2 A
352	DEC ID #4 Sensor 2 A
353	DEC ID #5 Sensor 2 A
354	DEC ID #6 Sensor 2 A
355	DEC ID #7 Sensor 2 A
356	DEC ID #8 Sensor 2 A
357	DEC ID #9 Sensor 2 A
358	DEC ID #10 Sensor 2 A
359	DEC ID #11 Sensor 2 A
360	DEC ID #12 Sensor 2 A
361	DEC ID #13 Sensor 2 A
362	DEC ID #14 Sensor 2 A
363	DEC ID #15 Sensor 2 A
364	DEC ID #16 Sensor 2 A
365	DEC ID #17 Sensor 2 A
366	DEC ID #18 Sensor 2 A
367	DEC ID #19 Sensor 2 A
368	DEC ID #20 Sensor 2 A
369	DEC ID #21 Sensor 2 A
370	DEC ID #22 Sensor 2 A
371	DEC ID #23 Sensor 2 A
372	DEC ID #24 Sensor 2 A
373	DEC ID #25 Sensor 2 A
374	DEC ID #26 Sensor 2A
375	DEC ID #2 Sensor 2 B

376	DEC ID #3 Sensor 2 B
377	DEC ID #4 Sensor 2 B
378	DEC ID #5 Sensor 2 B
379	DEC ID #6 Sensor 2 B
380	DEC ID #7 Sensor 2 B
381	DEC ID #8 Sensor 2 B
382	DEC ID #9 Sensor 2 B
383	DEC ID #10 Sensor 2 B
384	DEC ID #11 Sensor 2 B
385	DEC ID #12 Sensor 2 B
386	DEC ID #13 Sensor 2 B
387	DEC ID #14 Sensor 2 B
388	DEC ID #15 Sensor 2 B
389	DEC ID #16 Sensor 2 B
390	DEC ID #17 Sensor 2 B
391	DEC ID #18 Sensor 2 B
392	DEC ID #19 Sensor 2 B
393	DEC ID #20 Sensor 2 B
394	DEC ID #21 Sensor 2 B
395	DEC ID #22 Sensor 2 B
396	DEC ID #23 Sensor 2 B
397	DEC ID #24 Sensor 2 B
398	DEC ID #25 Sensor 2 B
399	DEC ID #26 Sensor 2B
400	DEC ID #2 Sensor 3 A
401	DEC ID #3 Sensor 3 A
402	DEC ID #4 Sensor 3 A
403	DEC ID #5 Sensor 3 A
404	DEC ID #6 Sensor 3 A
405	DEC ID #7 Sensor 3 A
406	DEC ID #8 Sensor 3 A
407	DEC ID #9 Sensor 3 A
408	DEC ID #10 Sensor 3 A
409	DEC ID #11 Sensor 3 A
410	DEC ID #12 Sensor 3 A
411	DEC ID #13 Sensor 3 A
412	DEC ID #14 Sensor 3 A
413	DEC ID #15 Sensor 3 A
414	DEC ID #16 Sensor 3 A
415	DEC ID #17 Sensor 3 A
416	DEC ID #18 Sensor 3 A
417	DEC ID #19 Sensor 3 A

418	DEC ID #20 Sensor 3 A
419	DEC ID #21 Sensor 3 A
420	DEC ID #22 Sensor 3 A
421	DEC ID #23 Sensor 3 A
422	DEC ID #24 Sensor 3 A
423	DEC ID #25 Sensor 3 A
424	DEC ID #26 Sensor 3A
425	DEC ID #2 Sensor 3 B
426	DEC ID #3 Sensor 3 B
427	DEC ID #4 Sensor 3 B
428	DEC ID #5 Sensor 3 B
429	DEC ID #6 Sensor 3 B
430	DEC ID #7 Sensor 3 B
431	DEC ID #8 Sensor 3 B
432	DEC ID #9 Sensor 3 B
433	DEC ID #10 Sensor 3 B
434	DEC ID #11 Sensor 3 B
435	DEC ID #12 Sensor 3 B
436	DEC ID #13 Sensor 3 B
437	DEC ID #14 Sensor 3 B
438	DEC ID #15 Sensor 3 B
439	DEC ID #16 Sensor 3 B
440	DEC ID #17 Sensor 3 B
441	DEC ID #18 Sensor 3 B
442	DEC ID #19 Sensor 3 B
443	DEC ID #20 Sensor 3 B
444	DEC ID #21 Sensor 3 B
445	DEC ID #22 Sensor 3 B
446	DEC ID #23 Sensor 3 B
447	DEC ID #24 Sensor 3 B
448	DEC ID #25 Sensor 3 B
449	DEC ID #26 Sensor 3B
450	DEC Fault status ID# 2
451	DEC Fault status ID# 3
452	DEC Fault status ID# 4
453	DEC Fault status ID# 5
454	DEC Fault status ID# 6
455	DEC Fault status ID# 7
456	DEC Fault status ID# 8
457	DEC Fault status ID# 9
458	DEC Fault status ID# 10
459	DEC Fault status ID# 11

460	DEC Fault status ID# 12
461	DEC Fault status ID# 13
462	DEC Fault status ID# 14
463	DEC Fault status ID# 15
464	DEC Fault status ID# 16
465	DEC Fault status ID# 17
466	DEC Fault status ID# 18
467	DEC Fault status ID# 19
468	DEC Fault status ID# 20
469	DEC Fault status ID# 21
470	DEC Fault status ID# 22
471	DEC Fault status ID# 23
472	DEC Fault status ID# 24
473	DEC Fault status ID# 25
474	DEC Fault status ID# 26
525	DEC Sensor 1 Current Alarm Status ID# 2
526	DEC Sensor 1 Current Alarm Status ID# 3
527	DEC Sensor 1 Current Alarm Status ID# 4
528	DEC Sensor 1 Current Alarm Status ID# 5
529	DEC Sensor 1 Current Alarm Status ID# 6
530	DEC Sensor 1 Current Alarm Status ID# 7
531	DEC Sensor 1 Current Alarm Status ID# 8
532	DEC Sensor 1 Current Alarm Status ID# 9
533	DEC Sensor 1 Current Alarm Status ID# 10
534	DEC Sensor 1 Current Alarm Status ID# 11
535	DEC Sensor 1 Current Alarm Status ID# 12
536	DEC Sensor 1 Current Alarm Status ID# 13
537	DEC Sensor 1 Current Alarm Status ID# 14
538	DEC Sensor 1 Current Alarm Status ID# 15
539	DEC Sensor 1 Current Alarm Status ID# 16
540	DEC Sensor 1 Current Alarm Status ID# 17
541	DEC Sensor 1 Current Alarm Status ID# 18
542	DEC Sensor 1 Current Alarm Status ID# 19
543	DEC Sensor 1 Current Alarm Status ID# 20
544	DEC Sensor 1 Current Alarm Status ID# 21
545	DEC Sensor 1 Current Alarm Status ID# 22
546	DEC Sensor 1 Current Alarm Status ID# 23
547	DEC Sensor 1 Current Alarm Status ID# 24
548	DEC Sensor 1 Current Alarm Status ID# 25
549	DEC Sensor 1 Current Alarm Status ID# 26
550	DEC Sensor 2 Current Alarm Status ID# 2
551	DEC Sensor 2 Current Alarm Status ID# 3
552	DEC Sensor 2 Current Alarm Status ID# 4
553	DEC Sensor 2 Current Alarm Status ID# 5
554	DEC Sensor 2 Current Alarm Status ID# 6

555	DEC Sensor 2 Current Alarm Status ID# 7
556	DEC Sensor 2 Current Alarm Status ID# 8
557	DEC Sensor 2 Current Alarm Status ID# 9
558	DEC Sensor 2 Current Alarm Status ID# 10
559	DEC Sensor 2 Current Alarm Status ID# 11
560	DEC Sensor 2 Current Alarm Status ID# 12
561	DEC Sensor 2 Current Alarm Status ID# 13
562	DEC Sensor 2 Current Alarm Status ID# 14
563	DEC Sensor 2 Current Alarm Status ID# 15
564	DEC Sensor 2 Current Alarm Status ID# 16
565	DEC Sensor 2 Current Alarm Status ID# 17
566	DEC Sensor 2 Current Alarm Status ID# 18
567	DEC Sensor 2 Current Alarm Status ID# 19
568	DEC Sensor 2 Current Alarm Status ID# 20
569	DEC Sensor 2 Current Alarm Status ID# 21
570	DEC Sensor 2 Current Alarm Status ID# 22
571	DEC Sensor 2 Current Alarm Status ID# 23
572	DEC Sensor 2 Current Alarm Status ID# 24
573	DEC Sensor 2 Current Alarm Status ID# 25
574	DEC Sensor 2 Current Alarm Status ID# 26
575	DEC Sensor 3 Current Alarm Status ID# 2
576	DEC Sensor 3 Current Alarm Status ID# 3
577	DEC Sensor 3 Current Alarm Status ID# 4
578	DEC Sensor 3 Current Alarm Status ID# 5
579	DEC Sensor 3 Current Alarm Status ID# 6
580	DEC Sensor 3 Current Alarm Status ID# 7
581	DEC Sensor 3 Current Alarm Status ID# 8
582	DEC Sensor 3 Current Alarm Status ID# 9
583	DEC Sensor 3 Current Alarm Status ID# 10
584	DEC Sensor 3 Current Alarm Status ID# 11
585	DEC Sensor 3 Current Alarm Status ID# 12
586	DEC Sensor 3 Current Alarm Status ID# 13
587	DEC Sensor 3 Current Alarm Status ID# 14
588	DEC Sensor 3 Current Alarm Status ID# 15
589	DEC Sensor 3 Current Alarm Status ID# 16
590	DEC Sensor 3 Current Alarm Status ID# 17
591	DEC Sensor 3 Current Alarm Status ID# 18
592	DEC Sensor 3 Current Alarm Status ID# 19
593	DEC Sensor 3 Current Alarm Status ID# 20
594	DEC Sensor 3 Current Alarm Status ID# 21
595	DEC Sensor 3 Current Alarm Status ID# 22
596	DEC Sensor 3 Current Alarm Status ID# 23
597	DEC Sensor 3 Current Alarm Status ID# 24
598	DEC Sensor 3 Current Alarm Status ID# 25
599	DEC Sensor 3 Current Alarm Status ID# 26

## Function Description – MI273 through MI297 – Signed Integer

### Bit 15 - Clear

NAME	BITS	FUNCTION DESCRIPTION
Fault Relay Active	0	Set if True
Sensor Missing – Sensor 1	1	Set if True
Sensor Missing – Sensor 2	2	Set if True
Sensor Missing – Sensor 3	3	Set if True
Calibration Fault – Sensor 1	4	Set if True
Calibration Fault – Sensor 2	5	Set if True
Calibration Fault – Sensor 3	6	Set if True
Power Fail Fault – Sensor 1	7	Set if True
Power Fail Fault – Sensor 2	8	Set if True
Power Fail Fault – Sensor 3	9	Set if True
Power Fault – Main Unit +5VDC	10	Set if True
Sensor End of Life – Sensor 1	11	Set if True
Sensor End of Life – Sensor 2	12	Set if True
Sensor End of Life – Sensor 3	13	Set if True
Configuration Reset	14	Set if True
Sign	15	Always 0

### Bit 15 - Set

NAME	BITS	FUNCTION DESCRIPTION
LOC – Sensor 1	0	Set if True
LOC – Sensor 2	1	Set if True
LOC – Sensor 3	2	Set if True
Over Range – Sensor 1	3	Set if True
Over Range – Sensor 2	4	Set if True
Over Range – Sensor 3	5	Set if True
Quick Under Range – Sensor 1	6	Set if True
Quick Under Range – Sensor 2	7	Set if True
Quick Under Range – Sensor 3	8	Set if True
Under Range – Sensor 1	9	Set if True
Under Range – Sensor 2	10	Set if True
Under Range – Sensor 3	11	Set if True
Not Used	12	Not Used
Not Used	13	Not Used
Not Used	14	Not Used
Sign	15	Always 1

### Function Description – MI450 through MI474 – Signed Integer

NAME	BITS	FUNCTION DESCRIPTION
Device Fault – (any fault)	0	Set for all fault conditions
Calibration Active – Sensor 1	1	Set During Calibration
Calibration Active – Sensor 2	2	Set During Calibration
Calibration Active – Sensor 3	3	Set During Calibration
Warm Up Mode	4	Set During Startup
Low Alarm Active	5	Set While Alarm Relay is Active
Mid Alarm Active	6	Set While Alarm Relay is Active
High Alarm Active	7	Set While Alarm Relay is Active
Future	8	
Future	9	
Future	10	
Future	11	
Future	12	
Future	13	
Future	14	
Not Used	15	

### Function Description – MI525 through MI599 – Signed Integer

- 0 = Normal Operation
- 1 = Caution
- 2 = Warning
- 3 = Alarm

## **Appendix C, Remote Relay Modules**

- Optional Remote Relay units:
  - A total of four remote relay units may be added to the modbus network.
  - Modbus ID numbers of the remote relay modules must be programmed for ID#30, 31, 32, or 33.
  - Input Remote Relay on all remote units is the local silence alarm.
    - Closing this input will silence the local alarm as well as the ModCon75 Alarm. Output O0 is for the local alarm output.

NOTE: If Zone Alarms are programmed as Latch, user can silence the alarm at the remote relay, but the Zone alarm will not clear until the unlatch input is initiated at the ModCon75 Controller.



**Table C-1. Remote Relay Module Specifications**

<b>POWER SUPPLY</b>		12 VDC or 24 VDC
PERMISSIBLE RANGE		10.2 VDC to 28.8 VDC with less than 10% ripple
MAXIMUM CURRENT CONSUMPTION		180 mA @ 24 VDC (pnp inputs) 220 mA @ 12 VDC (pnp inputs)
<b>DIGITAL INPUTS</b>		10 pnp (source) or npn (sink) inputs (NOTE 1)
NOMINAL INPUT VOLTAGE		12 VDC or 24 VDC (NOTES 2 & 3)
INPUT VOLTAGES FOR PNP (SOURCE)	12 VDC	0 to 3 VDC for Logic '0' 8 to 15 VDC for Logic '1'
	24 VDC	0 to 5 VDC for Logic '0' 17 to 28.8 VDC for Logic '1'
INPUT CURRENT		4 mA @ 12 VDC 8 mA @ 24 VDC
INPUT IMPEDANCE		3 K $\Omega$
RESPONSE TIME (except high-speed inputs)		10 mS typical
GALVANIC ISOLATION		None
INPUT CABLE LENGTH		Up to 100 meters, unshielded
<b>DIGITAL OUTPUTS</b>		6 relay outputs, 230 VAC/ 12/24 VDC
OUTPUT TYPE		SPST - NO relay
RELAY TYPE		Takamisawa (Fujitsu) JY - 12H-K or NAIS (Matsushita) JQ1A-12 V or OMRON G6B-1114P-12 VDC
ISOLATION		By relay
OUTPUT CURRENT		5 A max. (resistive load) 1 A max. (inductive load)
MAX. FREQUENCY		10 Hz
CONTACT PROTECTION		External precautions required
<b>DISPLAY</b>		STN, LCD display
ILLUMINATION		LED yellow-green backlight
DISPLAY SIZE		2 lines, 16 characters long
CHARACTER SIZE		5 x8 matrix, 2.95 x 5.55 mm
<b>KEYPAD</b>		Sealed membrane
NUMBER OF KEYS		15

**Table C-1. Specifications (continued)**

<b>RS485 SERIAL PORT</b>	Used for: <ul style="list-style-type: none"><li>• Application download/upload</li><li>• RS485 networking</li></ul>
(NOTE 4)	1 port
INPUT VOLTAGE	-7 to +12 V differential max.
CABLE TYPE	Shielded, twisted pair, in compliance with EIA RS485
GALVANIC ISOLATION	None
BAUD RATE	110 - 57600 bps
NODES	Up to 4
<b>OTHER DATA</b>	
CLOCK (RTC)	Real-time clock functions (date and time)
BATTERY BACK-UP	7 years typical for RTC and system data
WEIGHT	310 g (10.9 oz.)
OPERATIONAL TEMPERATURE	0 to 50°C (32 to 12°F)
STORAGE TEMPERATURE	-20 to 60°C (-4 to 140°F)
RELATIVE HUMIDITY (RH)	5% to 95% (non-condensing)
MOUNTING METHOD	DIN-rail mounted (IP20/NEMA 1) Panel mounted (IP65/NEMA 4X)
<b>NOTES:</b>	
1) All 10 inputs can be set to pnp (source) or npn (sink) via a single jumper and appropriate wiring	
2) All 10 inputs can function in 12 VDC or 24 VDC via single jumper and appropriate wiring	
3) npn (sink) inputs use voltage supplied from the controller's power supply	
4) RS232/RS485 is determined by jumper settings and wiring	

### Power supply, pnp (source) inputs

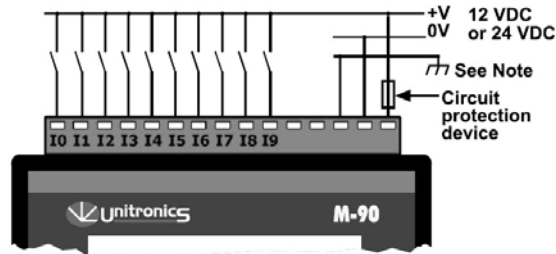

NOTE: To avoid electromagnetic interference, mount the controller in a metal panel/cabinet and earth the power supply. Earth the power supply signal to the metal via wire 10 cm or shorter. If conditions do not permit this, do not earth the power supply.

**Figure C-1. Power Supply, pnp (source) Inputs**

### Relay Outputs

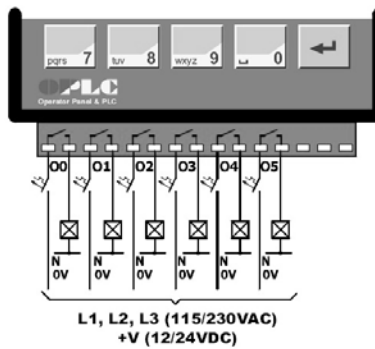

MODBUS ID 30	MODBUS ID 31	MODBUS ID 32	MODBUS ID 33
00 Local Horn	00 Local Horn	00 Local Horn	00 Local Horn
01 Zone 1 Alarm	01 Zone 3 Alarm	01 Zone 5 Alarm	01 Zone 7 Alarm
02 Zone 2 Alarm	02 Zone 4 Alarm	02 Zone 6 Alarm	02 Zone 8 Alarm
Input 10 Common	Input 10 Common	Input 10 Common	Input 10 Common
Local area silence	Local area silence	Local area silence	Local area silence

**Figure C-2. Relay Outputs**

## Jumper Settings

- Tables C-2 through C-5 indicate how to set a specific jumper to change the Controller functionality.
- To open the controller and access the jumpers, see FIGURES C-3 and C-4.

### **⚠ CAUTION**

Incompatible jumper settings and wiring connections may severely damage the controller.

**Table C-2. JP1 Digital Inputs Type**

TO USE AS	JP1
npn (sink)	A
pnp (source)	B

**Table C-3. JP2 Digital Inputs Voltage**

TO USE AS	JP2
12 VDC	A
24 VDC	B

**Table C-4. JP5, JP6 Power Supply Voltage**

TO USE AS	JP5	JP6
10.2 to 15.6 VDC	A	A
15.6 to 28.8 VDC	B	B

**Table C-5. JP3 Analog Input Type**

TO USE AS	JP3
Voltage input (default)	A
Current input	B

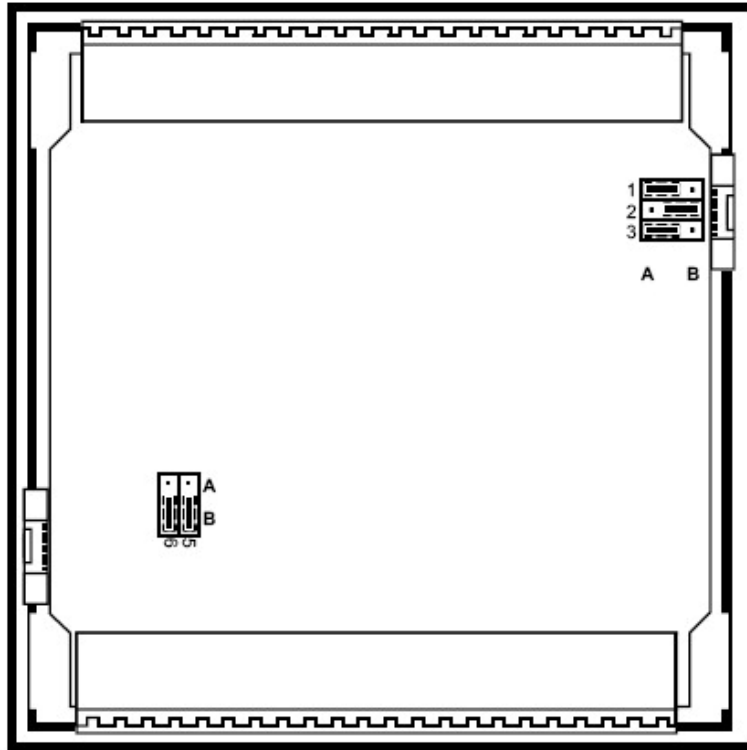

**Figure C-3. Shown Jumper Settings  
Cause the Controller to Function as Follows:**

DIGITAL INPUTS	npn, 24 VDC inputs
ANALOG INPUT	Voltage input
POWER SUPPLY	24 VDC

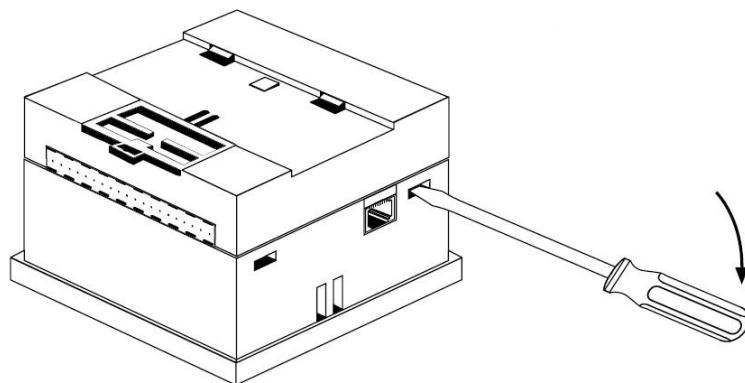

**Figure C-4. Opening the Controller Enclosure**

1. Locate the four slots on the side of the enclosure.
2. Using the blade of a flat-blade screwdriver, gently pry off the back of the controller (FIGURE C-4), exposing the controller's board.

## Appendix D, Event Retrieval Tools

MSA provides access to a data retrieval tool called DataXport that is available via the MSA support website. DataXport allows the user to view alarm and fault events logged within the ModCon75 Controller. DataXport saves the data logs in .ulp format. These data logs can be opened using DataXport's companion application, DataXIs, and the data can then be exported to Excel files.

Via DataXport, you can:

- View alarm and fault events logged within the controller.
- Access PLCs and log events via a direct, network, Ethernet, or modem connection.

To download this application tool, go to [www.msanorthamerica.com](http://www.msanorthamerica.com) , select "Fixed Gas Detection Instruments", then "Software Downloads". The DataXport User's Guide is located under "Fixed Gas Detection Instruments", "Controllers", "ModCon 75 Controller" under the Literature tab.